

PRODUCT CATALOGUE

Issue 5

£2

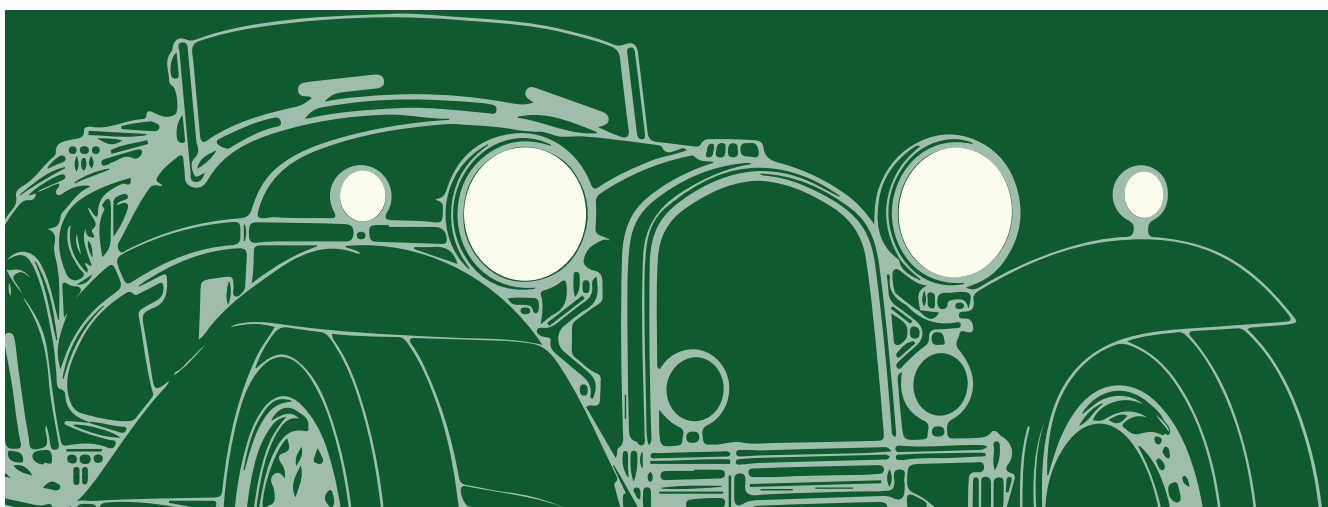

THE LEADING LIGHT

A wide range of components for
classic, vintage and kit cars

Aeroscreens | Wipers | Lights | Mirrors
Wiring Looms | Accessories



Stafford Vehicle Components is a trading entity of the Vintage and Classic Spares group including Vintage Supplies Ltd, The Complete Automobilst, Small Ford Spares, Classic Ford Spares, Flexolite, Classic Engine Parts, & Classic Bulbs



Welcome to the SVC motoring catalogue

SVC supply a wide range of parts and accessories for vintage and classic cars from our 15,000 square foot warehouse in Malvern, Worcestershire. We stock an extensive range of components for classic, kit cars and specialist sports cars – including aeroscreens, wiper systems, lights, switches, mirrors, looms, fans and much more. We sell products from most leading classic accessory brands and manufacture many new parts to a high specification.

This catalogue has been produced as a supplement to our secure website, as many customers request a paper guide to our product range to browse. We have worked to ensure a wide range of items are included, however many more parts are available – comprehensive details of all parts we stock are provided on our website www.s-v-c.co.uk along with the latest prices.

We understand that however comprehensive a website, it cannot answer all your questions – so if you'd rather talk, please call **01684 219863** – we would be very happy to hear from you! Finally, SVC is part of the Vintage and Classic Spares group so please visit our other websites to see all we can offer for your cars.



TABLE OF CONTENTS



04

Aeroscreens, Wind Deflectors, Helmets & Goggles



05

Badgebars & Badges



06

Brake System Components & Servos



07

Clips, Clamps, Washers, Seals & Ties



08

Electrical Accessories



11

Fuel Filler Caps & Necks



12

Fuel System Components



14

Gauges & Instruments



15

Heaters



16

Ignition System



19

LEDs, Bulbs, & Bulb Holders



23

Lighting

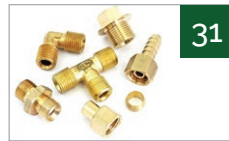

31

Metal Pipe & Fittings



32

Mirrors



34

OBP Tanks & Pedals



36

Oil Cooling, Oil System & Lubrication



44

Alternators, Dynalites & Starters



47

Steering Wheels & Pedal Rubbers



49

Stone Guards & Rims



50

Switches



54

Tools, Hardware, Consumables & Accessories



62

Washer & Wiper Systems



69

Water Cooling, Fans & Hose



72

Wiring Looms & Cable

Aeroscreens

Wind Deflectors, Helmets & Goggles

Our Brooklands and Auster Pattern aeroscreens are still manufactured the traditional way with polished aluminium die cast frames and chrome on brass fittings. Laminated glass is used for added safety. These are an essential addition to any vintage sports car.



Auster Aeroscreen Curved Top

SKU: 234C

Auster pattern with polished aluminium frame and brackets. Laminated glass, brackets for mounting on to wood. Overall size approx 349mm x 180mm. Fully adjustable with position maintained by a brass wing nut at one end.



Auster Aeroscreen Square Top

SKU: 234S

Auster pattern with polished aluminium frame and brackets. Square top laminated glass, brackets for mounting on to wood. Overall size approx 349mm x 180mm. Fully adjustable.



Brooklands Aeroscreen Curved Top

SKU: 460C

Brooklands Aeroscreen with curved top glass. Polished die cast frame and chrome on brass fittings. Laminated glass. Max height 185mm, width including wing nuts 400mm, hole spacing in feet 20mm.



Brooklands Aeroscreen Square Top

SKU: 460S KIT

Brooklands Aeroscreen with square top glass. Polished die cast frame and chrome on brass fittings. Laminated glass with the square top often used on pre-war cars. Max height 185mm, width including wing nuts 400mm.



Brooklands & Auster Curved + Scuttle Mount

460-SCUT & 234-SCUT

Polished die cast frame and chrome on brass fittings with a polished aluminium base designed to fit on the raised part of the scuttle on early sports cars. Laminated glass. Width including wing nuts 400mm.



MG Type

SKU: CA1150-MG

Perspex wind deflector with fixings to fit MGs and also may be used on many other vehicles, the wind deflector screen fixes with brackets to the end of the sports car type windshield frame, sold in pairs only.



Morgan Type

SKU: CA1150-MOR

Perspex wind deflector with fixings to fit Morgans and also may be used on many other vehicles, the wind deflector screen fixes with brackets to the end of the sports car type windshield frame, sold in pairs only.



Aeroscreen Spare Parts

SKU: VARIOUS

Replacement side legs, banjos, fastening wing-nuts and laminated glass to suit our aeroscreens.



Flat Rubber Glazing Strip

SKU: 518

Black rubber strip used for glazing into frames and mounting strip, available in various sizes and thicknesses.



Auster Screen Badge

SKU: 516AUS

Reproduction Auster screen badge. Solid aluminium. Raised rim and lettering. 18.5mm diameter. As originally fitted to the ends of various designs of Auster screen.



'Spitfire' style leather flying helmet

SKU: CA1081

A really good quality soft leather helmet with lower neck protection flap, enabling open air motoring in style and comfort. Made from best quality hide with a chamouis leather lining.



Leather motoring helmet

SKU: 753

A really good quality soft leather helmet, enabling open air motoring in style and comfort. Made from best quality hide, with a cloth lining.



Mk8 RAF Motoring Goggle Leather

SKU: 754-Mk8

Traditional style motoring goggles specially designed to ensure a snug and comfortable fit, RAF blue paint over solid brass frames, hand stitched soft leather. Angled split shatterproof/scratch resistant lenses.



Mk10 Motoring Goggle Leather

SKU: 754-Mk10

Traditional style motoring goggles specially designed to ensure a snug and comfortable fit, Soft leather padded surround, curved one piece shatterproof/scratch resistant lenses. Suitable for wearing over open-faced helmets.



Mk49 Motoring Goggle Leather

SKU: 754-Mk49

Traditional style motoring goggles specially designed to ensure a snug and comfortable fit. Solid brass frames with screw thread adjustable nose-bridge. Soft leather padded surround, Fully adjustable headband, lined with silicone strips.

Badge Bars

Badges, Plaques & Flags

19mm diameter stainless steel badge bars with chrome legs. We offer a choice of length and straight and cranked versions.



Badge Bar (Mono Post)
9"

SKU: BB15

Single mounting post. Chrome "Leg", stainless steel bar. Total leg length 103mm, bolt size 6mm.



Badge bar
15"/18"/22"/24"

SKU: BB15-BB24

Twin mounting post. Chrome "Leg", stainless steel bar 15"/18"/22"/24" long. Total leg length 103mm, bolt size 6mm



Desmo Badge Clamps

SKU: 696/696S

Badge Clamps "Desmo" style chrome or stainless steel. Height 37mm, length 38mm.



Spot Lamp Bracket
LUCAS Style

SKU: LUCBRAK

Chrome plated lamp bracket for use with badge bars—enabling the mounting of Lucas 700/576 spot/fog lamps on the ¾" or 1" Badge Bars.



Cast Desmo '613' badge bar lamp bracket

SKU: CA281

Chrome plated cast Desmo '613' pattern bracket for 19mm diameter standard badge bars. For mounting long range, spot lamp or fog lamp.

We stock a large variety of enamel, stainless steel, cast and self adhesive badges, please do look online for the full range.



GB letters

SKU: CA1159

Chrome on brass GB letters 84mm high, each letter attached by two screws and nuts from behind (hole centres 70mm).



Cast Aluminium UK plate

SKU: 900UKS

Oval cast aluminium UK plaque, with raised letters and rim, supplied unpainted, nice vintage pattern.



GB oval plaque (bottom mount)

SKU: CA1159-OV-S

Black stove enamelled oval plaque (190mm x 105mm) with chrome on brass GB letters (84mm tall).



Cast GB plate with marked manufacturer

SKU: 900

Oval cast GB plaque with manufacturer's mark, with raised letters and rim, supplied unpainted.



Cast Netherlands plate NL

SKU: 900NL

Oval cast NL plaque with raised letters and rim, supplied unpainted. Also IRL, D, F



Enamel flag badge

SKU: 591E

Patriotic national flag badge of England, George Cross, hard jewellers enamel badges, multi coloured, chrome backing approx 56mm x 35mm.



Crossed flags—chrome

SKU: CHEQUFB

Crossed chequered and Union flags—black and chrome. Self adhesive metal enamelled badge 25mm x 51mm



Country Origin Letter

SKU: 698

Heavy gauge chromium plated brass letters approx 88mm tall x 62mm wide, as available in early post-war years.



Various fixing spire clips and cups

SKU: various

A range of replacement badge fixing clips and top-hat post fixing cups.



AA vehicle members badge

SKU: 305C

AA vehicle members badge, from approx 1945 to 1967, yellow painted backing with chrome face.



3D Badge, self adhesive
SKU: WELSHBDG



3D Badge, self adhesive
SKU: SNSBDG



3D Badge, self adhesive
SKU: RAFBDG



3D Badge, self adhesive
SKU: GREBDG



3D Badge, self adhesive
SKU: ITFLAG

Brake System Components

Servos, Master Cylinders, Pipe, Hose & Fittings

We supply many different master cylinders to fit a wide variety of brake systems. We also stock brake reservoirs, servos, proportioning valves and braided hoses and fittings to allow you to fully customise your brake setup.



OBP Master Brake Cylinders

SKU: MASTCYL

Girling Type. Master cylinder. Remote unit. Threads: Push Rod: 5/16" UNF-Inlet: 7/16" UNF-Outlet: 3/8" UNF Bores = 0.625" / 0.7" / 0.75"



Single Fluid Reservoir

SKU: OBPCB004

This unit has no level sensor. Ideal for race cars and hydraulic clutch reservoir. Size: 80mm in height and 70mm across. 7/16" UNF 20TPI fitting.



Double Chamber Brake Reservoir

SKU: DOUBLERES

Low line double chamber remote brake reservoir with fluid level warning switch and bottom exit feed.



Brake Bias Proportioning Valve

SKU: OBPCB012

Recognised as the industry standard, This unit fully regulates the front to rear brake pressure.



Stainless Braided Reservoir Feed

SKU: OBPST001

Hose Spec-310mm Length, 7/16 UNF female each end, plus 7/16 UNF male fitting



Dual Circuit Remote Brake Servo

SKU: DUALSERVO

This is the only remote twin circuit (dual circuit) servo that we know of. Servo assistance comes in as the brake line pressure increases to a max boost ratio of 2:1



AP Lockheed Remote Brake Servo 1.9:1

SKU: LE72696

Made in the UK. Extremely high quality kit for single line brake systems-1.9:1 boost ratio 7" servo unit fitted to many cars in the 50's, 60's and 70's.



AP Lockheed Remote Brake Servo 3:1

SKU: LR18221

3:1 boost ratio 8" servo unit fitted to many cars in the 50's, 60's and 70's. A great add-on to any classic car for more stopping power. Adapt to just about any single line brake system.



AP Lockheed Remote Brake Servo 2.3:1

SKU: LR17792

2.3:1 boost ratio, 7" servo unit fitted to many cars in the 50's, 60's and 70's. Servo with fitting kit. Commonly used on Ford Cortina 1600E & GT, 120E Corsair GT and V4.



Fixing kit for Lockheed Servos

SKU: LRKIT

Fixing kit for Lockheed remote servos. Includes bracket, hardware and connecting pipes. Included with LR18230, LR17793, LR17792, LR18221, LE72696



Seamless Copper Alloy Brake Pipe

SKU: KBP

1/4" and 3/16" OD Kunifer brake pipe 25 foot roll. NB-A flaring tool is required to form the necessary seating.



Stainless Braided Brake Hose

SKU: TFE

Extruded Teflon tube with stainless steel single wire braid cover commonly used for braking systems. Sold by the metre.



Brake & Clutch Fluid Resistant Hose

SKU: BFRH

Use for gravity feed to master cylinder from remote reservoir. 8mm ID & 9.5mm ID. Sold by the metre.



Single Hose Clamp Black

SKU: POCS

Hose or tube clamp. Often used as bulkhead clamp to hold 1/4" brake pipe. 6mm-22mm, single or double



Rubber lined steel 'P' clip for tube

SKU: ZPRC

Popular fitment for holding 1/4" brake pipe and other hoses. Available sizes 6mm to 50mm



Male to Male Adaptors & Bulkhead Versions

SKU: Various

Over 50 different sizes and thread fitments



Banjo Bolts & Bleed Nipples

SKU: Various

35 types of single and double banjo bolts and caliper bleed nipples.



Compression Fittings for TFE Braided Hose

SKU: Various

Male & Female, straight & swivel. 20+ sizes, plus brass olives & replacement sockets



Banjo & Angled Fittings for TFE Braided Hose

SKU: Various

Straight & angled banjo fittings. Angled compressions fittings.



Other Adaptor Fittings

SKU: various

Tees-male & female, swivel and straight adaptors Compression Tees and Connector Blocks

Clips & Clamps

Washers, Seals & Ties

All those little clips, clamps, fixings and thingamabobs. Having the correct fixing in good condition makes working on the vehicle so much easier and is essential for reliability.



Double Eared 'O' Clips
SKU: ZPOC

Zinc Plated, 13 different sizes to suit 5mm to 31mm tubes and hoses.



Gemelli Wire Hose Clip
SKU: GWC

Super equal pressure grip hose clip, galvanised wire. Original equipment to many cars. 8 sizes.



Nut & Bolt Clamps
SKU: ZNBC

Zinc plated mild steel nut and bolt fuel pipe clips plus all Stainless Steel Mikalor Supra W4 clamps.



O Clamps
SKU: POCS & POCD

Single and Double. Fire retardant polyamide plastic. 6 to 22mm OD pipes, tubes, hoses and wiring cables.



Plastic & Brass P Clips
SKU: NPC & 522

Black nylon 'P' clips, brass P clips as well as self adhesive nylon clips.



Rubber Lined Steel 'P' Clips
SKU: ZPRPC

One of the most useful clips available. Rubber lined using a 1.5mm thick E. P. D. M. rubber. Holes to suit M6.



Metal Saddle Clips
SKU: Various

Brass and Zinc plated steel saddle clips.



Ties
SKU: Various

Cable (zip) ties, double loop, screw mount, saddle mounts, eyelets and stainless steel ties.



Washers & Seals
SKU: Various

Bonded seals, Fibre washers, solid & folded copper washers, shake-proof washers.



Worm Drive Clips
SKU: Various

Stainless Steel Jubilee brand. Plus Tridon brand with a narrower 8mm band width and smaller screw size.



Double Eared 'O' Clips

Double eared 'O' clips are designed specifically for the fastening of any flexible hose or tube to a rigid connection where permanent, reliable and high performance joints are required. They are widely used for maintenance and OEM applications, mainly on air, fluid, gas, steam lines and hydraulic applications.

SVC 'O' clips are made from zinc plated W1 steel to exacting engineering standards so they may be used in both static and dynamic applications under both internal and exposed conditions. Simplicity and high speed of attachment make them ideal for DIY hose system assembly with SVC part number OCPINCER.

Why use an 'O' Clip?

- The neat design is unlikely to catch or rub on anything.
- The clips give perfectly even distribution of pressure
- Permanent and tamper proof
- Low unit cost.
- When correctly installed, they are much more reliable than a worm-drive or threaded fastening.

Application Instructions

To achieve optimum performance:

1. Selection of the correct size of O Clip is **essential** Measure with the fitting inserted in the hose.
2. The inside Diameter of the Clip should be approx 0.04mm (1/64") larger than the overall diameter of the tube plus fitting in order to obtain maximum joint efficiency.
3. Use the correct pincers - **NOT pliers** - that will flatten the "ears"
4. Clamp one ear partially at first,
5. Fully clamp the second side
6. Now fully clamp the first ear.
7. To remove - use side cutters on the tool to cut an 'ear'.



SKU: OCPINCER



Before Clip is Closed



Correctly Closed

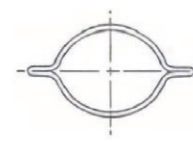

Incorrectly Closed
(This can fracture the clip wall)

Electrical Accessories

Control Boxes, Horns, Relays, Flashers & Fuses

We carry a huge range of electrical accessories, with many IVA suitable products, branded components and quality reproduction parts made to the original specification and style. This is a sample of our full range.



FIA Battery Master Switch

SKU: IS4

Competition engine 'Kill' switch FIA approved. Complete with ceramic resistor, Spare Key & Instructions.



Battery Cut Off Master Switch

SKU: 445

Battery master switch, good value alternative, black plastic body, red removable plastic key. Usually mounted in earth lead.



Battery Cut Off

SKU: DISCAR2RS

Simple yet effective battery master switch- fits on the battery post -screw knob detaches if required.



Battery Master Switch

SKU: CA1369

Sturdy panel mounted switch, similar to Lucas ST360 (SSB106). Requires 19mm hole in panel. Well made reproduction part.



Battery Master Cut Off

SKU: SSB103

Reproduction of Lucas SSB103. As used on Austin Healeys. Requires hole size approx 43 mm diameter.



Battery Master Cut Off

SKU: 463P

Equivalent to Lucas ST330, 76605. Mounting flange (53mm hole centres). Knob marked with 'OFF' and arrow.



Control Box Regulator & Cut-out Type RB106

SKU: 10505

6 volt or 12 volt 22A voltage regulator/control box with Lucas push-on terminals or screw posts. Equivalent to Lucas Part Numbers NCB101 and RB106.



Control Box Regulator & Cut-out Type RF95

SKU: RF95

12 volt or 6v reproduction units. Base 115mm x 87mm x approx 95mm overall height. 9 screw terminals.



Regulator & Cut-out Type RB340

SKU: RB34030

12V 30A Dynamo Voltage Regulator. Equivalent to Lucas part number NCB133. Applications include Ford, MG, Morris and Wolseley. Also 22amp version.



Replacement Regulator Lids

SKU: Various

NOS & re-manufactured lids. Black & Brown. Super reproductions.



12V Alternator Voltage Regulators

SKU: NCB144

Equivalent to Lucas NCB144 or NCB148. 3 or 4 terminals. Neg or Pos earth versions



12V Mechanical Voltage Regulator

SKU: NCB120 & NCB119

12V 11A Regulator equivalent to Lucas Part Number RB108 NCB118/ NCB120.



SF4 Type Fuse Box

SKU: 908

Fuse box equivalent to Lucas type SF4, four glass fuse type fuse box. Centre screw to lid top, black bakelite.



SF5/2 Type Fuse Box

SKU: 307

Single fuse box, black bakelite cover, takes glass type fuses. Equivalent to Lucas type fuse box SF5/2, 37260



Fuse box-6 Fuse

SKU: 659

Fuse box, black finish, accepts 6 modern type Bosch/continental cartridge fuses.



Multi Blade Fuse Box

SKU: FBB

4, 6 or 8-Way Fuse Box. Standard Blade fuse box complete with transparent cover and gasket.



LED Blade Fuse Box

SKU: FBBL

1 x 5mm positive power input stud which feeds the blade fuses. Red LED shows when blown. 4, 6 or 10 way.



7FJ Type fuse box

SKU: 37552

7FJ fusebox for four Glass Type Fuses for later MGB, TRs, Cobra & many other cars.



Chrome Rim Horn

SKU: CA882

6 v or 12v-black with chrome ring, 105mm diameter. Complete with mounting bracket.



Chrome Rim Horn

SKU: CA883

Large and noisy 12 volt electric horn. Approx 150mm diameter.

Electrical Accessories

Control Boxes, Horns, Relays, Flashers & Fuses



Klaxon Horn 12v
SKU: 348

The traditional sound of a Klaxon 00000-HA. Chrome, Black or Red horn. Very loud at 110db. These are the best quality Klaxons on the market.



Lucas Windtone 12v
SKU: WHHT & WHLT

Quality reproduction of Lucas 9H Windtone Horn. Low & High tones. Used on many British cars & motorcycles 1964 onwards.



Audible Warning Buzzer
SKU: BUZZ

Fit behind dash. 12 volt. Another reminder for indicators!



Large Bull Horn 12v
SKU: CA1387

Variation of traditional 'bull horn', making plenty of noise (115db). Horn is operated by a control lever in the cockpit.



Windtone Horns Pair
SKU: WTH

High & low notes. This type of horn set was fitted to many British cars of the 1940s & 1950s—provides a robust "hoot".



Junction Box
SKU: 308, 309, 375

Reproduction of original Lucas type round, 2, 4 or 6 terminal, black bakelite junction box with screw cover.



Junction Box-8 way
SKU: 8WAYJB

Black phenolic junction box with waterproof glands at each end and waterproof gasket all round.



Junction Box 3 Terminal
SKU: 308A

Re-manufactured C30L black bakelite junction box with push on cover, 42mm diameter body.



DB10 Relay 12v
SKU: 461

Relay used where brake & indicator rear lights are used on the one bulb. Application, MG, Morris Minor etc.



Starter Relays 12v
SKU: SRB

SRB type Starter & Change Over Relays used on many British cars. 4 types



Fused Relay 12v
SKU: 8002-12

30 amp. Fitted circuit fuse & mounting bracket. 6.3mm Lucar blade connectors.



Fused Relay 6v
SKU: 8002-6

30 amp. Fitted circuit fuse & mounting bracket. 6.3mm Lucar blade connectors.



Relay Mounting Block
SKU: 8002MB

Relay mounting block to keep your wiring neat & tidy.



Change Over Relay 12v
SKU: SRB411

20amp Equivalent to Lucas part numbers SRB411 & 33374.



Starter Solenoid 12v
SKU: SRB3

External square type equivalent to Lucas SRB325. Fitted to many British cars.



Remote Starter 12v
SKU: CA1400

Solenoid starter button that you can mount under the bonnet. Equivalent to Lucas part SRB316, 2ST



Flasher Unit 6v or 12v
SKU: 922

3 Lucas terminals. L goes to live, P to warning light, X goes to indicators.



Clockwork Flasher Unit
SKU: 414

Flasher unit/indicator switch 6v or 12v. Self cancelling after 20/25 seconds.



LED Flasher Relay
SKU: LEDFLASH

For vehicles changed in full or part to LED tail lights and or indicators/turn signals. 12v, 6v, Pos & Neg earth available



Flasher Relays 6v & 12v
SKU: SFB

Traditional canister & box type relays, 2 & 3 pins. Over 10 types stocked.

Electrical Accessories

Control Boxes, Horns, Relays, Flashers & Fuses

We carry a huge range of electrical accessories, with many IVA suitable products, branded components and quality reproduction parts made to the original specification and style. This is a sample of our full range.



12v Hazard Flasher Kit
SKU: SFB300

Illuminated knob & flasher unit for mounting underneath the dash. Equivalent to Lucas part number SFB300 (30269).



LED resistor (pair)
SKU: 900WR

One needed for each LED indicator to prevent rapid 'hyper' flashing if not using an LED flasher unit.



Dash Socket & Plug
SKU: 960

Two panel mount sockets (red and black) and one plug. Often used for inspection lamps.



Cigarette Lighter
SKU: CA1408B-L

Black engraved push knob, with illumination ring for night time use.



Chrome cigar Lighter
SKU: CA1408

Requires 22mm diameter hole in dash panel for fitting. Illuminated version also.



Inspection lamp
SKU: HL3

12v/24w with Polycarbonate lens. Clamp for mounting. Cigar lighter adapter and crocodile clips.



Immobiliser
SKU: IMMOB

Interrupts up to 4 circuits in the wiring loom. Supplied with dash socket, LED warning light, wiring and two keys. Instructions included.



Windscreen Demister
SKU: CA1384A

Re-manufactured period windscreen demister equivalent to the 'Brooks Standard Model' 6 Volt.



Windscreen Demister
SKU: CA1384B

Re-manufactured period windscreen demister equivalent to the 'Brooks Standard Model' 12 Volt



Aerial-Retracting
SKU: CA1366B

Fully retractable stainless steel aerial, with 1.2 metres of aerial cable. Under hang of 230mm



Roof Mounted Aerial
SKU: CA1366

Supplied with 2 metres of cable. 530mm long, 890mm extended, spring base.



H4 Headlamp Wiring
SKU: 5825W

Wired terminals, sleeve and grommet BS specified wiring and wire colours.



H4 Harness + Sidelight
SKU: 58241

With wedge T10 side light bulb holder that accepts capless bulbs. Approx 60cm



Lighter Plug
SKU: CIGPLUG

Cigar socket plug. Solder on your appliance. Unfused, 12V or 24V, 10A maximum



12v USB Charger
SKU: USB

12V auxiliary power/ cigarette lighter socket USB charge with LED light



Have you visited the Vintage & Classic Spares Website?

See the other parts of the Vintage & Classic Spares group of companies

- Articles on Customers' Cars
- How our parts are made
- Hints and Tips
- Newsletters
- New Product News

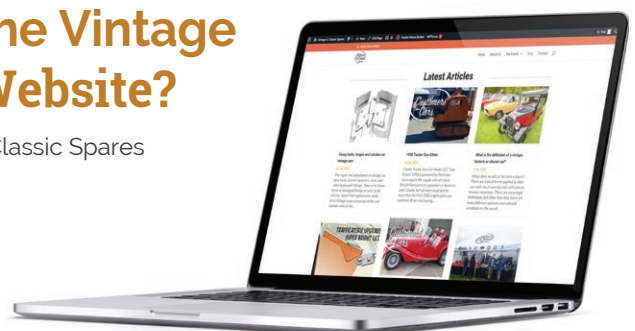

www.vintageandclassicspares.co.uk

Fuel Filler Caps & Necks

Grommets & Neck Hose

Polished aluminium & chrome Aston, Bonora and Monza fuel caps in a range of sizes. Caps have a threaded base and are supplied with gaskets to allow adjustment of orientation when mating with the various accessories SVC supply. A selection of our filler neck adaptors, fuel resistant neck hose and rubber filler grommets.



Monza Filler Cap
SKU: 111

Internal thread 2 1/2" (63mm) x 16 TPI. Release button is opposite the hinge under the lid. 4 other sizes



Bonora Lever Top Cap
SKU: 968

Reproduction of Bonora lever top filler cap, period fitting to Singer and MG of the 1930's



Aston Type Cap
SKU: 115

Roller catch. Chrome on brass or polished alloy. Several sizes.



Wilmot Breedon Cap
SKU: CA1431

Locking type, chrome plated 2 point bayonet fitting. MGB, Spitfire, etc.



Presto' Chrome Filler
SKU: PREST1

Die cast with lock. Fits to 2" flexible hose, as fitted to post war sports cars.



Flange Funnel Insert
SKU: LIK1

Locking filler cap insert for fitting into flange funnels. note this will NOT fit the 2" cap parts.



Filler Adapter Neck
SKU: 117

Flanged adapter neck - thread 2" (51mm) x 18 TPI. Alloy or chrome on brass



Flanged Filler Neck
SKU: 120A

Flanged alloy neck with internal spigot for 2" (51mm) pipe. Accepts LIK1 filler cap.



Flanged Filler Neck
SKU: 118A

Aluminium neck with internal spigot for 2" or 2.1/4" pipe, thread 2.5" x 16TPI - will accept the LIK1 locking filler cap.



Flanged Filler Neck
SKU: 119A

Aluminium neck with internal spigot for 2" or 2.1/4" pipe, thread 2.75" x 16TPI - will accept the LIK1 locking filler cap.

Black moulded rubber fuel filler neck pipe grommets to replace old perished items. 20 sizes stocked.



Filler Adapter Neck
SKU: 118

Flanged adapter neck - thread 2 1/2" (63mm) x 16 TPI. Brass, alloy or chrome.



Filler Adapter Neck
SKU: 165A

Plain adapter neck - external thread 2 1/2" x 16 TPI, for welding or 63mm ID hose.



Filler Adapter Neck
SKU: 165

Plain adapter neck in brass - external thread 2 1/2" (63mm) x 16 TPI.



Fuel Filler Grommet
SKU: 84404

Morris 8 series E saloon and Z van. Internal approx. 44mm. Angle of slope is approx. 25 degrees.



Fuel Filler Grommet
SKU: 86916

Moulded part, black. 62mm internal diameter, fits panel hole 70mm diameter, 102mm overall diameter.



Fuel Filler Grommet
SKU: 86906

Moulded part, black 52mm internal diameter, fits panel hole 62mm diameter, 85mm overall diameter.



Fuel Grommet Oval
SKU: 86903

Moulded part for 45mm pipe. Panel hole 68mm x 55mm, overall 79mm x 66mm.



Fuel Filler Grommet
SKU: 86901

Moulded part, black 48mm internal diameter, fits panel hole 56mm diameter, 103mm overall diameter.



Fuel Filler Neck Hose
SKU: FFHFLEX

Flexi hose with steel spring - made from fuel resistant rubber 2" or 1/4" ID



Fuel Filler Neck Hose
SKU: FFHWRAP

Wrapped hose made from fuel resistant rubber 2" or 1/4" ID

Fuel System Components

Pumps, Repair Kits, Filters & Regulators

Facet Fuel Pumps are the leading name in after-market fuel pumps. SVC stock both solid state pumps and cylindrical pumps for road, fast road and competition use.



Facet Red-Top Pump
SKU: 1337C

Cylindrical 12v fuel pump kits. Normal road use, Fast Road or Competition versions



Facet Posi-Flow 12v
SKU: PFP

Neat electronically-controlled pump in a nylon casing. Low, medium & high flow versions.



Facet Fuel Pump 12v
SKU: 1337-S

Solid state fuel pump kits. 3 versions for normal road use, fast road or competition



6V Low Pressure Pump
SKU: PFP6LP

High quality 6V solenoid fuel pump that can be fitted in-line.



12V Fuel Pump
SKU: PFP12H

High quality 12V solenoid fuel pump that can be fitted in-line. Pos or neg earth.



AC Fuel Pump Repair
SKU: FPBD

Rebuild kits for AC type mechanical fuel pumps. 11 different kits available for 100s of applications.



1337-C Cylindrical Red Top

An industry standard for over 60 years, these lightweight compact pumps can be found in almost every conceivable application. With output ranges up to 170.3 litres/hr and 0.68 bar, these pumps will provide high-performance output for everything from racing cars to heavy duty agricultural and construction machinery. E10 Compatible

PFP Posi-Flow Universal Electronic

12V, 4 to 7psi, 145 litres/hr. Compatible with all fuel additives. Eliminates Vapour Lock. No Flooding, ensuring restarts on hot days. Two wire design, self priming. Made in the USA

1337-S Solid State Fuel Pump Kit

Outputs up to 132.5 litres/hr and 0.68 bar. Facet Cube Pumps are self-priming with a dry lift capacity of 120 inches. Two universal models provide complete coverage for all low and high-pressure carburettor applications for cars & vans. Compatible with petrol, diesel, Ethanol fuels and additives.

30 models of Mechanical Fuel Pumps for classic vehicles



Mechanical Fuel Pump
SKU: 7950183

Pump assembly with hand prime lever. Many Ford applications including 8hp and 10HP from 1945.



Mechanical Fuel Pump
SKU: 7950695

Pump with filter. Equivalent to AC part No. 7950695. Ford 105E models 1961 onward.



Mechanical Fuel Pump
SKU: 461-128

Fuel pump assembly, as AC part No. 461-128 Many Ford, Morgan and Lotus applications.



Mechanical Fuel Pump
SKU: 7950108

Applications include Triumph TR2, TR3, TR3A, TR4 and TR4A. Morgan +4 1954-1969



Mechanical Fuel Pump
SKU: 461-208

Applications include Reliant Robin 600, 700 and 750cc 1973 to 1975. Equivalent to AC part number 461-208

Fuel pressure regulators compatible with most fuels (except methanol) and with a variety of end connections, glass and allow bowl options, mounting accessories.



Petrol King Regulator
SKU: FPR008R

Fuel pressure adjustment may be set between 1.5psi and 5psi. Union size 1/8" NPTF Female-see our adaptors to suit your system.



Petrol King Regulator
SKU: FPR007

Glass bowl version of FPR007-with 8mm hose tails. WITH pressure gauge take off. E10 compatible. Combined fuel filter and regulator.



Petrol King Regulator
SKU: 1337-REG

Designed to improve carburettor feed. Fuel flow is steady and constant, giving a better idle and rapid starting.



Mounting bracket
SKU: MRB001

For use with Filter King and Petrol King pressure regulators.



Replacement Filters
SKU: Various

Replacement paper and gauze type filter elements and glass bowls for fuel filters.

Fuel System Components

Filters, Taps, Hose & Fittings

All the pieces need to connect the fuel system:- shut-off taps, change-over taps, non-return valves, elbows, hoses tail fittings, joiners and 'T' pieces. **This is just a small sample**



Non Return Valves
SKU: NRV

Prevent fuel siphoning back to the tank. Low opening pressure of approx 0.3psi.



Non Return Valves
SKU: NRV

Fuel, Oil and Water. Suitable for use with electric oil pump systems.



Non Return Valves
SKU: NRV

High quality forged brass non return valve with Viton seal.



Non Return Valves

A worthwhile and low cost addition to fuel systems. Prevents the fuel draining back to the tank (siphoning) after running. With cars not used every day, this can help with much quicker starting as the fuel lines will still be full.

Some are suitable for use with electric oil pumps and will prevent siphoning and drainage problems with dry sump oil systems.



Change-over taps
SKU: Various

2 or 3-way valves to select main or reserve fuel tanks.



Fuel shut off valve
SKU: EFT3

Maximum working pressure 300psi. 3/8" NPT female



Fuel shut off valves
SKU: Various

Various fuel, oil and vapour cut-off valve taps.



Male/Female elbow
SKU: 973S-elbow

Ideal for use with our 973S for a 3/8 BSP fuel tank feed.



Hose Tail Fittings
SKU: Various

A small sample of hose joining fittings



Banjo Union
SKU: 367 / 368 / 369

Solder type banjo unions with bolts and washers.



Banjo with Compression
SKU: BANCOM

Single banjo couplings with compression fittings -various threads and tube sizes.



Hose Tail Banjo
SKU: Various

For low-pressure (to 15psi) carburettor installations.



Hose Tail Banjos
SKU: WEBBAN

T-piece & 90 degree bend banjos for fuel pipes.



Banjo Bolts
SKU: BB

Single & double types in steel and aluminium.

Fuel hose, finishers and pressure gauges to complete and test your fuel system installation.



Fuel Hose
SKU: Various

Transparent reinforced hose, black neoprene reinforced hose and stainless braided. Multiple sizes, per metre.



Acetylene Tubing
SKU: 733

Red rubber tubing 5mm bore with 1.5mm wall for acetylene gas burning lamps.



Hose Finishers
SKU: HEC & HEF

Rubber end caps and hose finisher clamps for braided hose. Multiple sizes



Fuel Pressure Gauges
SKU: FPG

Various fuel pressure gauges and inline sender/adaptors



Fuel Pressure Test Kit
SKU: FPGK100

Includes Sytec Fuel Pressure Gauge 0-15 Psi (0-1 Bar), Gauge Adaptor, fittings and pipe.

Gauges & Instruments

Gauges, Rims, Senders & Pressure Switches

The SVC range features many gauges supplied by Smiths Instruments, makers of the highest quality gauges and instruments for classic cars. We stock Smiths classic gauges, AC Cobra specific gauges, a wide range of gauge rims many other gauge accessories. A sample below.



Fuel Gauge & Sender Unit Package

SKU: FL-FUEL
52mm gauge, mounting kit, vertical sender unit for fuel tanks 5 to 27" deep.



Oil Pressure Gauge & Sender Package

SKU: FL-OIL
52mm oil pressure marked 0 to 100 PSI and pressure transducer/sender unit.



Water Temp & Sensor Unit Package

SKU: FL-WATER
Marked 40 to 120 degrees centigrade and thermocouple/sensor unit.



52mm Voltmeter

SKU: FL-VOLT
52mm marked 8 to 16 volts. With mounting kit, 12 volt backlight bulb and holder.



Oil Pressure Gauge-White face

SKU: OP160W
Mechanical instrument with precision machined brass movement.



Smiths Classic Clock

SKU: SCC
With bulb holder, bulb, and mounting clamp. As used on Minis, but is suitable for pretty well any application.



Smiths Classic Fuel Gauge

SKU: SCFG
This is a bi-metallic Gauge and you will need a matching Fuel Tank Sender and a Voltage Stabiliser.



Smiths Oil Pressure Gauge-Mechanical

SKU: SCOPM
0-100 lbs psi. Oil pressure pipe, together with the relevant adaptors is available separately.



Smiths Voltmeter

SKU: SCV
52mm in diameter with a half chrome bezel, white figures on a black dial reading from 11 to 15 volts.



Smiths Water Temp & Oil Pressure Gauge

SKU: CA1310
Combined duplex gauge. 56.5mm diam, with standard 2" (52mm) body fitting through panel.



Smiths AC Cobra Speedometer

SKU: COB1
100mm ANTICLOCKWISE as on the original Cobra, reads 0 to 180 mph. Supplied with bulb & mounting clamps.



Smiths AC Cobra Tachometer

SKU: COB2
100mm diameter 0 to 8000 rpm. Electronic operation Switchable for 4,6,8,12 cylinder engines.



Smiths Oil Pressure Gauge - Mechanical

SKU: COB3
Mechanical operation-you will require an oil pressure pipe, an adaptor and maybe a T piece to connect.



Smiths Cobra Ammeter

SKU: COB6
52 mm diameter gauge with white figures on a black quadrant dial reading from -50 to +50 amps. .



Cobra Fuel Gauge

SKU: COB7
52mm diameter gauge with 12 volt illumination. For use with bi-metallic tank senders.

We stock all the supporting parts for your gauges. Senders and adaptors for fuel, oil and water, voltage stabilisers, mounting brackets, connecting pipes, replacement rims, glass, 'O' rings, bulbs and bulb holders. A sample of the range can be seen below.



Fuel Sender Units

SKU: TS1, TS2, TS3
Top Mounting, Side Mounting, Euro Spec and Cobra fuel tank sender



Voltage Stabiliser

SKU: VSN & VSP
Stabiliser to regulate the voltage supply. One stabiliser is required per three gauges. Pos or Neg versions



3 Gauge Holder 52mm

SKU: 52-3GH
Mount under the dash to hold 3 standard 52mm Smiths gauges.



Pressure Switches & Gauge Adaptors

SKU: Various
Oil pressure switches, oil gallery T pieces, oil temperature adaptors, Y pieces and water temp adaptors.



Gauge Rims & Parts

SKU: Various
Replacement full and half 'v' rims for 52, 80, 100 and 125mm sizes. New glass and 'O' ring seals. Replacement bulb holders.

Heaters

Cabin Heaters, Demisting, Valves & Fittings

A range of classic heater units offering simple installation plus a variety of fan speed and demister options. Including the Clayton barrel heater—used on many 1960's cars—and the Xenos heater, perfect for many kit and classic vehicles.

The Finland Heater

SKU: FINHEAT



Connect into the water cooling system. Complete with demister air hose, 3 Speed Fan. Heater matrix box sizes 120mm x 120mm x 290mm. Heater motor protrudes 110mm. A compact high performance after market heater system from long established ELITE KL. Often included as standard equipment in many quality kit cars. Demister nozzles are also available. Black powder coated steel body, plastic cased blower unit, copper/brass radiator construction.

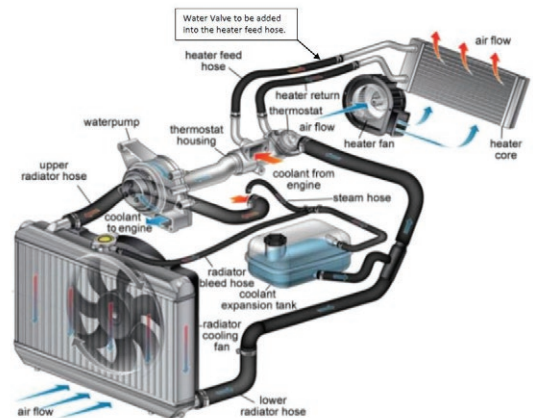

Not just a touch of comfort, a heater is an essential safety requirement to keep the windscreen clear on cold mornings and make your vintage or classic a practical car.

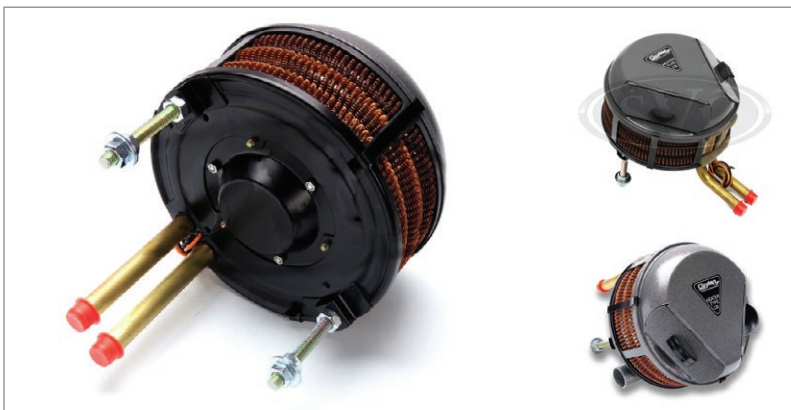

Clayton Classic Barrel Heater

SKU: BARRMK

The Clayton heater was used in 1960's Jaguar saloons as well as cars from Daimler, Alvis, Lea Francis, Armstrong Siddeley, Rover and the Land-Rover S1. It is also similar to the Smiths unit fitted to Morris, TR3, Austin-Healey and Jaguar XK. This is a single speed 12V motor. The unit can be specified with a 6V motor for an additional charge as a special order item. Available with straight or angled water pipes and with or without demist outlet.



Xenos Cabin Heater

SKU: XENOS

The Xenos Cabin Heater 2 Speed Heater. Available with or without demister outlets. W 251mm x D 196mm x H 115mm.



Heater Water Valve
SKU: COW

Classic car heater water valve. Operated by a cable. This is a 'pull to close'. Manufactured for Clayton type heaters but can be used with other systems.



Clayton Electric Fan
SKU: CFSS

12volt fan motor for Clayton Heaters. Pos. or Neg. earth vehicles. Can rotate in either direction.



Water Valve Cable
SKU: COWV-cable

1.6m long cable with a loop at either end. The loop fits the water valve, the other end can be modified to suit.



Demister Escutcheon
SKU: CHDEMIST

Chrome Demister Escutcheon. L 185mm x W 17mm, fixing holes centre to centre 170mm



Heater Element
SKU: HEMP

Element with motor plate for the Smiths circular heater. This type of heater was fitted to many classic cars including Morris Minor, Land Rover Series I & II etc.

Ignition System

Coils, Condensers, Contact Sets

A range of quality coils to suit all classic and vintage car applications including regular 6 and 12V coils—with push in and acorn nut connections—as well as Lucas standard and super sports coils, offering a stronger spark. On the SVC website, each coil alternative is tagged with a range of equivalent part numbers to make selection easier.



Early Lucas Type 12v Coil

SKU: COIL9

Reproduction of original Lucas coil fitted between late 1930's and mid 1950's. With screw in/acorn nut lead connection.



12V Super Sports Coil Lucas DLB105

SKU: COIL8

Lucas non ballasted sports coil 12V. Gives a stronger spark than the standard COIL4 or COIL5. Lucas part number DLB105.



12v Lucas Non Ballasted Coil DLB100

SKU: COIL6

12-volt Lucas non-ballasted coil with screw-in type HT lead with acorn connector. Primary coil resistance is 2.9 ohms & secondary resistance is 10.9 k/ohms



12V Non ballasted coil as Lucas DLB101

SKU: COIL4

Push in top cable terminal. Twin Lucar connections. Lucas standard and sports/high output versions of this coil are also available—see parts COIL5 and COIL8.



6V Super Sports Coil as Lucas 406697 and HS6

SKU: COIL7

Non Ballasted Sports Coil. Gives a stronger spark than the standard COIL1 or COIL3. Suitable alternative to many Lucas part numbers including 406697 and HS6.



Condensers—what do they do?

Condenser is just an old name for a capacitor. The usual explanation is that it gives the current from the coil a path to flow when the points are open—thus reducing arcing and prolonging the life of the points. However the engine will not run properly without a functioning condenser, so it is more than this. The condenser aids in the rapid collapse of the magnetic field generated by the windings in the coil.



It then discharges (AFTER the spark has occurred at the plug) back through the coil's primary windings to produce an oscillation needed to prime the coil to begin the next charge cycle.

Usually fitted inside or clamped to the body of the distributor it is easy and cheap to replace, with a lifespan of approx 20,000 miles. A failing condenser/points system will cause misfires, rough running and difficulty starting.



Condensers

SKU: COND

A range of 23 types of condenser for traditional ignition systems with contact sets/points.



Distributor Doctor Condensers

SKU: COND

We stock Distributor Doctor versions of popular fitments. These are very high quality condensers made to the original specification for high levels of performance and reliability.



Contact Sets

SKU: CSET

A huge range of contact sets to fit Lucas, Ford, and Delco-Remy distributors. Re-manufactured, NOS (New Old Stock) and Distributor Doctor items. All searchable by part numbers, distributor or vehicle application on the SVC website.

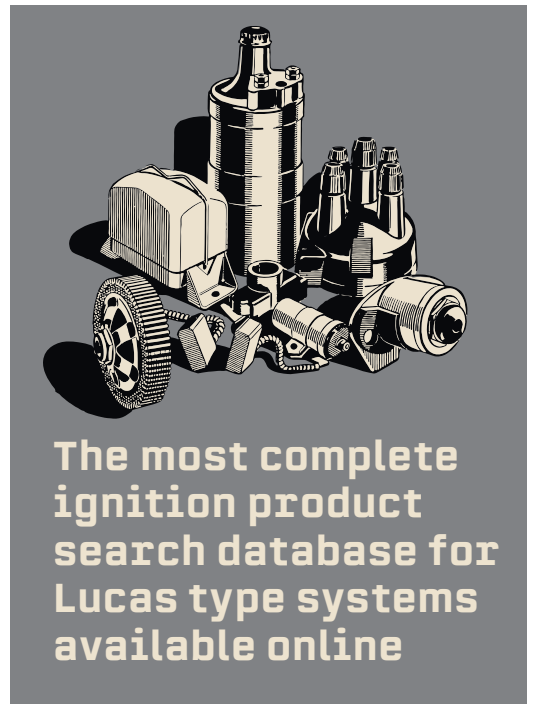

The most complete ignition product search database for Lucas type systems available online

Ignition System

Rotor Arms, Distributor Caps

A collection of **over 35 Rotor Arms** and **over 50 Distributor Caps** fitted to a wide range of vehicles. A sample of popular fitments is shown below, including British made, premium arms from the Distributor Doctor. If your vehicle is not shown, the SVC ignition parts database will help you find it.



Premium 6 Cylinder Red Rotor Arm

SKU: ARM1

Premium part from the Distributor Doctor. As Lucas 407106, 418731 and 421312. Aston Martin, Alvis, Lagonda, Bristol.



Rotor Arm Equivalent to Lucas Part DRB106C

SKU: ARM3

Popular British applications include Triumph-TR5/6, Vitesse, T2000, 2500; Jaguar-6 cylinder engines to 1975; MG-MGC; Austin Healey



Equivalent to Lucas DRB105, 400052

SKU: ARM7

High quality arm for a wide range of early applications including Austin, Citroen, Commer, Healey, HRG, Humber and many more



Equivalent to Lucas No. DRB195, RA95,

SKU: ARM9

Popular applications include Land Rover V8, Range Rover V8, Rover P5B, Aston Martin V8, TVR, Rolls Royce and Bentley



Equivalent Lucas part DRB703C, 54420904

SKU: ARM11

As Lucas part DRB703C, 54420904, RA3 and DRB703. Popular applications include Triumph-Spitfire MkI-MkIV, GT6, Vitesse



Equivalent to Lucas DRB133, 54401133, RA93

SKU: ARM14

Popular applications include Jaguar-XJ6 Series III 4.2, XJS 3.6 to '87, MG-Metro Turbo '82-'84. Fits distributor 45DM6



Equivalent to Lucas DRB432, 21941802, RA32

SKU: ARM20

Popular applications include Ford Fiesta, Escort, Capri Consul, Granada, Vauxhall, BMW, Saab 95,96, 99, VW and Volvo



Equivalent to Lucas DRB700, 60375003

SKU: ARM25

Popular applications include Saab 99 (Triumph Engine) Triumph Dolomite, TR7, Vauxhall 1600cc 1800cc, 2000cc 2300cc and Carlton



Equivalent to Lucas 400051, RA1, 410610

SKU: ARM6

Fitted to a wide range of vehicles to approx 1973. Applications include: Morris Minor, Austin Healey-100/4, Sprite; Mini, 59-74



Equivalent to Lucas DRB752C, RA2

SKU: ARM12

Late 105E, Fiesta 1976+, Escort mark 1 & 2, Cortina & Capri 1300 & 1600 1968-70, Corsair, Zephyr 4, Zephyr 6 & Zodiac 1968-72



Distributor Cap Lucas 409635

SKU: DCAP2

Late '40s applications-Austin, Citroen, Commer, Humber, Jowett, Hillman, Morris, MG, Singer, Standard, Sunbeam Talbot & Triumph



Equivalent to Lucas DDB111, 409563

SKU: DCAP7

Cap for Lucas DKY4A D2A distributors. Popular applications include: Ford 100E '53-61, MG TB-TF



Equivalent to Lucas DDB101, 422905, DC1

SKU: DCAP11

Popular applications include Morris Minor, Austin Healey Sprite, Mini 59-74 Side entry MG MGB '62-67, MGA, Midget



Equivalent to Lucas DDB112, DC12, 54426838

SKU: DCAP37

Distributor cap equivalent to Lucas part numbers DDB112, DC12 and 54426838. Popular applications include Triumph Dolomite sprint



Equivalent to Lucas DDB194, 54400270, DC94

SKU: DCAP46

Popular applications include MGB, Leyland Sherpa and Rover 2000. Fits distributor 43D, 45D4, 48D



Equivalent to Lucas DC42, DC43, DC54, DC32

SKU: DCAP30

Popular applications include Ford Fiesta, Escort, Capri, Cortina as well as many other applications including VW, Volvo, and Saab



Equivalent to Lucas DDB152, DC452

SKU: DCAP24

Equivalent to Lucas part DDB152, 54410627 and DC452. Popular applications include Jaguar-XJ6 Series III 4.2, XJS 3.6 to 87



Equivalent to Lucas Part Number 417178

SKU: DCAP43

Six cylinder side entry distributor cap. Applications include Aston Martin, Lagonda, Morris and Wolseley.



Equivalent to Lucas DDB754, 54420889, DC4

SKU: DCAP28

Popular applications include Ford Fiesta, Escort, Consul, Cortina, Capri, Corsair, Sierra, Transit, TVR Vixen



Equivalent to Lucas DDB153, 54401925

SKU: ARM25

Popular applications include Jaguar-XJ12 Series I and 2, XJ12 Series III pre HE, XJS V12 pre HE, E Type Series III

Ignition System

Spark Plugs, Brushes, Clips and Bearings

A range of over 100 NGK and Champion spark plugs for over 2000 classic and vintage vehicle applications, A comprehensive selection of ignition system accessories



Spark Plugs

SKU: SPC

An extensive range of over 110 Champion and NGK spark plugs that cover over 2000 vintage and classic vehicle model applications from over 130 vehicle marques. Our application database presents a choice of Champion or NGK plugs where available for your vehicle, as well as advising the recommended plug gap for each make of plug.

Where direct equivalent products are no longer available for some older plugs and applications, SVC list the modern equivalent and note whether the available plug may require an 18mm to 14mm thread insert for example.



Angled Suppressed Spark Plug Cap

SKU: 0.595.00

HT cap, black phenolic moulding with carbon suppressor. Supplied with grommets making it waterproof, or can be used without grommets to better suit older vehicles



Straight Suppressed Spark Plug Cap

SKU: 0.292.00

HT cap, black phenolic moulding with carbon suppressor, overall length 93mm inc. Removable rubber grommet. Cap screws into end of cable.



WCX600 Suppressed Spark Plug Terminal

SKU: WCX600

Spark plug suppressed terminals, embossed 'CHAMPION', 90 degree angle (side entry) cable which screws on to ignition wire, black.



Straight Unsuppressed Spark Plug Cap

SKU: 0.292.UN

Straight, non-suppressed, Hypalon spark plug cap, black, complete with terminal.



Spark plug adaptor-14mm/18mm

SKU: 452

Fit a 14mm plug to a 18mm plug hole, enabling customers to take advantage of the wider heat range of 14mm plugs.



HTC Unsuppressed Spark Plug Terminal

SKU: HTC

Straight spark plug terminal, as original early Champion. A non-suppressed terminal with fixed screw tip that screws into the cable core.



Straight Insulator Cover For Distributor Or Coil

SKU: 009-11COV

Insulator cover for distributor cap or coil terminal-use with part numbers 006-03 or 921 depending on connection



Angled Insulator Cover For Distributor Cap

SKU: 006-13COV

Insulator cover for distributor cap terminal part number 006-13



Ignition Terminals & Connections

SKU: VARIOUS

Ignition system HT lead terminals and connections



HT Nuts, Plug washers, Terminals & Clips

SKU: Various

Various HT spade end terminals, wire clips, spark plug brass nuts and folded plug washers.



Spare Spark Plug Holders

SKU: Various

Cast aluminium for spare spark plugs on vintage cars. 4 & 6 way to take 10, 14 & 18mm plugs. Various styles.



Distributor Driving Dog

SKU: DDOG1 & DDOG2

Replacement driving dog for Lucas type distributor. Supplied with cross pin. EN8DM grade steel.



Distributor Bronze Bushes and Bearings

SKU: Various

Oil porous bronze bearings and roller bearings. Various sizes to suit most distributors.



Replacement Distributor Cap Clips

SKU: DCLIP

Various replacement clips to suit Lucas type distributor caps.



Distributor Cap Brush

SKU: DBRU1 & DBRU2

Equivalent to Lucas part numbers 418856, 604110451, 404435, 404435W10 and 451260



Ht Ignition Cable 7mm Black

SKU: 416

Looks very similar to the original rubber covered lead, but it is covered with a soft matt plastic which will withstand oil/heat etc.



Ht Ignition Cable-Cotton Braided

SKU: 611

Braided lead with copper core, red/yellow, red/black, yellow/black, yellow/green, yellow/red or plain black. 6.70mm diameter.

LEDs, Bulbs, & Bulb Holders

Halogen, Incandescent, LED Panels, Warning Lights

Over 700 incandescent (conventional tungsten filament), halogen and LED bulbs for all applications. Head, Spot and Fog lamp, Stop and Tail, Warning and indicator, Side Instrument, Panel and Festoon bulbs. 6, 12 and 24V bulbs with a huge range of bases for car, commercial vehicle, motorcycle and scooter applications.

Headlamp Bulbs

120+ conventional (tungsten filament) and Halogen headlamp bulbs. Options for all vintage and classic applications.



12v 60/55w H4 P43T Base Headlamp

SKU: B472

12V H4 bulb rated at 60/55W with standard fit P43T base. Clear glass with black cap. E Marked.



12v 100/80W H4 P43T Base Headlamp

SKU: B484AS

All Season bulb, Produces a crisp blue tinted light. Adverse weather conditions. **Off road use only.**



6v 35/35W P36D Base HALOGEN Bulb

SKU: B6721BHB

A bright halogen upgrade for 6V British Pre-focus headlamp bulbs with twin transverse filaments.



12v 45/40W BOSCH BA20D base Headlamp

SKU: BT528

12V bulb rated at 45/40W. BA20D double contact base. Double filament. Clear glass 35mm diameter.



12v 48W SBC BA15D Base Headlamp Bulb

SKU: B27B

12V bulb rated at 48W. Double contact BA15D base. Single V filament. Clear glass.



6v 45/36W BA21D Base Headlamp Bulb

SKU: B5911B

40mm diameter clear globe. BA21D double contact 3 pin Marchal type base. Double filament.



6v 25/25W APF P15D 30 Base bulb

SKU: B5655

American Pre Focus double contact base. Double Filament 35mm glass diameter.



12v 45/40W ASY UEC P45T base bulb

SKU: B410Y

12V bulb rated at 45/40W. Asymmetric UEC P45T base. Yellow glass globe 41mm diameter. E marked.



12v 35/35W T19 PX15D 25.1 Base Bulb

SKU: B3606

Double contact base. Double Transverse filament. Pre-focus headlamp application.

Head, Spot & Fog

90+ types of head, spot and fog lamp bulbs



12v 55w H3 PK22S Base Spot Bulb

SKU: B453

12V Halogen H3 bulb rated at 55W, PK22S base. Clear glass. E marked.



12v 55W H2 X511 Base Spot & Fog Bulb

SKU: B479

12V H2 Halogen bulb rated at 55W. X511 Base. 31mm total height. E marked.



6v 24W P36S Base Spot & Fog Bulb

SKU: B160

6V bulb rated at 24W, Single transverse filament. British Pre-focus single contact base.



12v 42W BOSCH P15S 30 Base Head & Spot

SKU: BA5678

42W, American Pre-focus single contact P15S 30 base. Single transverse filament. 35mm glass diameter.

Festoon

50+ types of festoon bulb for interior, number plates, indicators, etc.



24v 21w H3 15X42mm Festoon Bulb

SKU: B275

24V Festoon bulb rated at 21W. 15mm glass diameter, 42mm long.



6v 3w 6x30mm Festoon Bulb

SKU: B16B

6V festoon bulb rated at 3W, 6 x 30mm, single filament, clear glass.



12v 18w 15x42mm Festoon Bulb

SKU: B270B

12V rated at 18W. 15mm glass diameter, 42mm long. Commonly used as an Indicator bulb.



12v 10w 8x36mm Festoon Bulb

SKU: B257B

12V festoon bulb rated at 10W, 8mm glass diameter, 36mm long.

LEDs, Bulbs, & Bulb Holders

Halogen, Incandescent, LED Panels, Warning Lights

Stop & Tail

25+ conventional stop & tail bulbs. Small globe versions for when space is tight.



12v 21/5W BAY15D Base Stop & Tail
SKU: B380BHD

Offset pin double contact base, 25mm globe diameter. Double transverse filament. Heavy Duty Long Life.



12v 23/8W BAY15D Base Stop & Tail
SKU: BA4879

12V bulb rated at 23/8W Double transverse filament. Brighter alternative to B380.



12v 21/5W BAY15D RED Stop & Tail
SKU: B380BR

For a red LED version of this lamp please see part number B380LEDR



12v 21/5W BAY15D Compact Stop & Tail
SKU: B3212A

SMALL (19mm) clear glass bulb—suitable for lamps where space is constrained.

Side & Panel Bulbs

150+ Side light, Instrument, panel and warning bulbs. Coloured and wedge bases.



12v 5W BA15D Base Side Bulb
SKU: B209B

5W, BA15D double contact cap, 19mm diameter globe. Single filament. E marked.



12v 5W MES E10 Base Instrument Bulb
SKU: B208

12V bulb rated at 5W, MES E10 base. Single filament. 15mm diameter globe (G15).



12v 6w Wedge T10 Base & Panel Bulb
SKU: B2886

Xenon bulb rated at 6W, T10 wedge W2.1x9.5D. Clear glass 10mm diameter.



12v 6w Wedge T10 Base & Panel Bulb
SKU: B286A

Amber bulb rated at 1.2W, T5 wedge base. W2 x 4.6D. Amber tubular glass 5mm

Indicator Bulbs

14 types of clear and Amber indicator bulbs



12v 21w SCC BA15s Base Amber Indicator
SKU: B343B

Amber bulb rated at 21W, BA15S single contact base, 25mm Amber glass..



12v 21w WEDGE T20 Amber Indicator
SKU: B382CLA

Capless Amber bulb rated at 21W, T20 wedge base, W3 x 16D. Amber glass 20mm



12v 21w BAU15S Base OSP Indicator
SKU: B586

25mm clear glass bulb. BAU15S Offset pins. Single contact base.



12v 27/7W W2.5x16Q P27/7W Base
SKU: B3157A

12V Amber bulb rated at 27/7W with black plastic W2.5x16Q base. .

Other Bulbs

Bus Bulb, miniature halogen, rough service, torch bulbs



24v 21w SBC BA15D Base Bus Bulb
SKU: B822

24V Pearl bulb rated at 24W with BA15D base and pearl 38mm diameter globe.



12v 20w LBC B22D Base Bus Bulb
SKU: B809A

12V bulb rated at 20W, B22D double contact base, Pearl glass 38mm diameter



12v 20w MCC BA9S Miniature Halogen
SKU: B433

Single contact BA9S base. Clear tubular clear glass 9mm diameter.



240v 60w B22D Rough Service Bulb
SKU: RS60BC

B22D bayonet cap. Rough service. Workshop inspection lamp application.

LEDs, Bulbs, & Bulb Holders

Halogen, Incandescent, LED Panels, Warning Lights

Bulbholders

50+ types for bulbholders for your vehicle lighting project or repair.



Replacement BA15 Bulb Holders

BA15SBH & BAY15DBH

16.4mm x approx 23.5mm long. Single (equal pin) or double (offset pin) contacts.



1130 Lamp Bulb Holder Double Contact

SKU: 1130BH-DC

1130 Lucas torpedo type side lamp bulb holder. BAY15D base bulbs



H4 Headlamp Bulb Holder-Ceramic

SKU: H4BHC

Socket ceramic connector. 21mm high, 27mm wide and 24mm long



Convert 211 'Duolamp' Lamps to Stop & Tail

SKU: 211-CONV

Bulb holder sleeve & pig tail wires to fit 211 series 'Duolamp' type lamps

LED Headlamp & Spot Bulbs

An expanding range of LED upgrades for classic vehicles.



LED Headlamp Bulb PX15D 25.1 Base

SKU: PX15D25.1

High quality 16 x Cree LED upgrade. 6v, 12v, 24v warm white.



Performance H4 P43t Classic White LED

SKU: P43TLED-PP43

High quality upgrade for H4 lamps with the P43T base. Low current draw.



LED Headlamp-BOSCH BA20D Base

SKU: BA20DLED-P43

Performance upgrade for Bosch headlamp bulbs with BA20D base.



LED Headlamp with LENS-SBC BA15D base

SKU: BA15DLED-H43L

Bright white Premium high power LED lens lamp upgrade for SBC BA15D



High performance H4 P43t Bright White LED

SKU: P43TLED-PP60P

Powerful, quality upgrade (with mini cooling fan). Excellent low beam cut-off.



Warm White Headlamp-SCC BA15S

SKU: BA15SLED-S30AX

Upgrade for SCC BA15S head and spot lamp bulbs from the '20s to the '50s.



Performance H1 P14.5S Warm White LED

SKU: H1LED-PP30

Powerful, high performance lighting with reduced current consumption.



Compact Performance H3 PK22S Classic White LED

SKU: H3LED-P30

A great LED upgrade for classic style fog, reversing and spot lamps.



LED Headlamp with LENS-H4 P45T base

SKU: P45TLED-H43L

Lens produces super light output with well defined level dipped beam.

LED Stop & Tail

A range of stop and tail bulbs for all applications in white, Warm White and Red



12V LED Stop & Tail SBC BA15D base

SKU: B381LEDR

Combined dual brightness Stop & Tail (Brake & Rear) functionality. Very low current draw



Warm White & Red 6V (POS) LED Combined

Combined Number Plate Illumination and Stop and Tail lamp for 6v positive earth systems.



Warm White & Red 12V LED Combined BA15D

Good contrast between stop & tail light outputs. Great combination lamp. Ideal for Lucas Type L582 lamps.



Warm White 6V LED Stop & Tail-BAY15D

In testing, comparable in brightness to 18/5W bulbs. Very low current draw-over 75% less than incandescent

LEDs, Bulbs, & Bulb Holders

Halogen, Incandescent, LED Panels, Warning Lights

LED Festoon

20+ types of LED festoon bulb for interior, number plates, indicators, etc.



White 12V LED Festoon lamp-11x39mm

SKU: B239LEDW-B

180 degree bright white light from 6 x SMD 3014 LEDs. Very low current draw-over 75% less than incandescent.



White 6V LED Festoon lamp-15x39mm

SKU: B1240LEDW-A

These LEDs are brighter than 5050 LEDs and hence the bulb features a finned aluminium heat sink.



White 12V LED Festoon lamp-11x39mm

SKU: B239LEDW-A

Equivalent fitting to B239B. 360 degree/all round bright light from 12 x SMD 5050 LEDs.



White 12V LED Festoon lamp-11x42mm

SKU: B270LEDW-A

Equivalent fitting to B270B and B273B with brightness comparable to 21W. 360 degree light.

LED Side, Panel & Instrument Bulbs

55+ Side light, Instrument, panel and warning bulbs. Coloured and wedge bases.



Warm White 6, 12 & 24V LED Instrument & Panel lamp

SKU: Bg8gLEDWW-B

80 Lumen Osram BA9S multi-directional warm white lamp with diffused glass bulb. BA9s base.



12V LED Instrument & Panel lamp-MES E10

SKU: B208LEDW-B

Bright White 50 Lumen LED 12V lamp with flat LED cluster for single direction light applications.



12V LED Side lamp-WEDGE T10 base

SKU: B501LEDW-C

Brighter in testing than T15 bulbs B922 (10W) and comparable to B955 (16W). Very low current draw



Amber 12V LED Instrument & Panel lamp

SKU: B501ALEDA

Amber LED lamp with T10 WEDGE base comparable in brightness to c5W incandescent lamps.



Add Indicators to Lucas ST38 Stop & Tail Lamps

SKU: ST38LP-RAW

Conversion kit for Lucas ST38 'Pork Pie' type Stop & Tail lamps-to Stop, Tail, Number plate & Indicators.

Part of our new range of surface mount LED upgrade boards. Complete lamps also available.



Add Indicators to Lucas ST51 SPLIT lens D lamps

SKU: ST51LP-RAW

Conversion kit for Lucas ST51 'D Lamp'-to Stop, Tail, Number plate & Indicators.

Part of our new range of surface mount LED upgrade boards. Complete lamps also available.

Warm White & Amber 6V & 12V LED Combined Side & Indicator lamp-SBC BA15D fitting

SKU: CSILEDWW

Part of our very popular new multi-function LED range.

A great compact and bright solution for easily converting classic sidelights to sidelight/indicator functionality. Bright or Warm white light for sidelight function, changing to very bright AMBER for indication (the white light cuts while indicating)

Ideal for the classic Lucas 1130 Torpedo type sidelamp, keeping the original appearance, but with modern function and safety. Use with a twin contact bulbholder such as 424 or 1130BH-DC and an LED electronic flasher unit if required.

Lighting

Sidelights, Interior, Dashboard and Warning

The finest collection of classic front sidelights. A very wide range of interior, dashboard and warning lights. Vintage, classic and modern styles with badge and colour lens options.



Side/Indicator Lamp 1130 type-Chrome
SKU: 297B-IND

Modified Torpedo-side/wing lamp. Chromium-plated brass body with Toby badge. Takes 2 capless bulbs.



Side Lamp 1130 type-Plain 'Red dot' tell tale
SKU: 297A

Double filament BA15D bulb holder-allows combined side and flasher bulb to be fitted; see CSILEDWW.



Toby Bulls Eye Side Light
SKU: CA1010

Reproduction CAV pattern Torpedo side lamps, chrome or nickel plated. 'Toby' badge on top.



LD109 pattern (round base)-Gloss black
SKU: g18-RB

Reproduction of Lucas LD109 type side lamp, approx 51mm diameter x 63mm long. Red dot on top.



Large Sidelamp Lucas Type VS45-6
SKU: 592

Large sidelamp equivalent to the Lucas VS45-6 type, 90mm diameter x 85mm deep, with glass lens.



L490 Type Sidelamp
SKU: 393

Re-manufactured side lamp to the L490 pattern as used on Jaguar Mk2, early XK and Armstrong Siddeley, etc.



Side, Rear or Indicator Equivalent to Lucas 594
SKU: 993

Flush back indicator lamp approx 72mm rubber back, stainless steel rim with plastic or glass lens.



L632 Type Indicator & Front Side Lamp
SKU: 632L

MGA, Morris Minor, Austin 1100, 1300 & Moke. Lens 80mm approx, total diameter with rim 96mm



Land Rover Front Side Light
SKU: 300LC

Land Rover front side light 73mm outer diameter. Takes a BA15S bulb. LED upgrade lamps and kits are available



L677 Lucas Sidelight and Indicator Lamp
SKU: L677

Side and Indicator Light for MGB, Spitfire Mk II. 150 mm long x 55 mm. Made with original Lucas tooling.



Dash Lamp Type Df41-'Toby' Medallion
SKU: 289T

Equivalent to Lucas type DF41 lamp, chromium cowl with 'Toby' medallion on top, black flange (70mm x 37mm)



Dashboard Illumination Lamp
SKU: 352

Nice dashboard lamp with helmet cover. Fits through metal dash hole approx 17mm.



Classic MG interior Boot Light Lamp
SKU: BHA5040

Small plastic interior lamp fitted to MGB, Austin Healy Sprite and MG Midget 1967 to 1979 as well as others.



Jewel Warning Lamp-As Lucas WL13 Type
SKU: JEWEL

As used on a number of high quality vehicles including Aston Martin. Red, Amber, Green & Blue.



Lucas WL15 Type Warning Light
SKU: SPB392

Dashboard warning light with hexagonal fronted lens and black or chrome bezel.



Warning Lamp As Lucas WL3-Chrome or Black
SKU: 842

Slotted screw bezel, chrome or black plastic body fits through dash (19mm hole). A good reproduction.



Warning Light-Panel Mount-Blue Main
SKU: CA1235BM

Printed with Main Beam symbol. Rear body black plastic, fits through 16mm panel hole.



Chrome Rim, Green Indicator Twin Arrow
SKU: WL2ARROW

Fitted with BA7S bulb holder and 12V 2W bulb as standard. 6.3mm Lucar terminals.



Dash Warning Lights Amber Black Rim
SKU: WLBRAM

Diameter 16mm approx. Hole required 12.5mm approx. Amber.



Button LED Green
SKU: LEDBUTSPA

Small LED side repeater Diameter of the rubber surround is 28mm, the lens is 19mm.

Lighting

Free Standing Headlights

Always known as lighting specialists, SVC stocks and custom builds a large range of light units from free-standing 5¾" and 7" headlights to premium vintage 8", 9" and 10" diameter lamps.



5 ¾" Free Standing Satin Black Headlamp
SKU: 1267B

Powder coated steel (ideal for painting body colour if needed). Round domed lens, without sidelight.



5 ¾" Free Standing Stainless Headlamp
SKU: 1267S

These are ideal for Morgan 3 wheelers, Austin 7s and 7 type Kit Cars amongst others.



7" Free Standing Stainless Headlamp
SKU: AS700SF

Wipac Freeform lens gives a fantastic light output and a sleek look. 7" Domed lens, with or without sidelight.



7" Black Body & Stainless Steel 'Toby' Headlamp
SKU: AS700MBS

Wipac Quadoptic lens, Toby branded. LHD, RHD. Configure bulb & harness to suit.



Dominator Race Headlight Black
SKU: 1260B

Small headlights for Off Road & Racing Use Only. Whilst they are "E" marked, they are not fully road legal.



8 ½" Free Standing Projector Headlamp
SKU: L140

Authentic reproduction of the L140 headlamp used on many British cars in the 1930s and 40s. Handspun in brass before polishing & plating. With Toby badge.



8 ½" Free Standing Projector Headlamp
SKU: L148

Authentic reproduction of the L148 headlamp used on many British cars including Morgan, Rover, Talbot and Wolseley. A significantly deeper lamp shell than L140



9" Free Standing Projector Headlamp
SKU: L150

Authentic reproduction of the L150 headlamp as used on a number of British cars in the 1930s and 40s. Shown with hinged stoneguard (option available on all).



9 7/8" Free Standing Projector Headlamp
SKU: L165

Authentic reproduction of the L165 headlamp used on many British cars in the 1930s and 40s. Available chrome plated or finished with gloss black shell & chrome rim.



9 7/8" Free Standing Projector Headlamp
SKU: L166

Authentic reproduction of the L165 headlamp used on many British cars in the 1930s and 40s. As the L165, but with a much deeper lamp shell with Toby badge.



New Range of Reproduction Vintage Projector Headlamps





L140 Bi-Flex

Detailed recreations of the pre-war Lucas type 140, 148, 150, 165 and 166 series lamps with 100s of vintage car applications

8", 9" and 10" diameter brass lamps with a choice of shell depth, handmade in Britain. Options include:

- All chrome finish or chrome rim with black body
- Diffused glass or fluted glass lenses
- Plain rims, bracketed or hinged stone guards
- Bi-flex bars to enhance projection and appearance
- Choice of incandescent or specialist LED bulbs



Authentic Daisy-head screw catch, cast & plated



Bi-flex bar option with Toby medallion



Hinged & bracketed options for stone-guards

Lighting

Headlamp Assemblies, Nests & Parts



Ford 1932 Stainless Steel Headlights

SKU: B-13000-QS

9 1/4" chrome on brass reflectors, original pattern lens. Official Ford products, show quality.



10" Free Standing Stainless Headlamp

SKU: CA1279

Large polished stainless steel headlamp units. Patterned shallow dome glass lens



7" Headlamp Visor

SKU: VISOR

Headlight peak for 7" lights. Stainless steel, clips behind inner headlight rim.



PL700 Tripod design light unit RHD

SKU: PL700RHD-HAL

Reproduction PL700 type unit with tripod design featuring a PL 'Shield' badge-takes popular H4 bulb.



7" Value Headlamp Unit UK RHD with Sidelight

SKU: 747DRP

Suitable for halogen, direct replacement for sealed beam units. Standard H4 P43T fitting.



7" British Pre-Focus With Side Lamp Hole

SKU: E493A-13011

7" Headlamp unit for British Pre-focus type bulbs, equivalent to Lucas 700 type.



7" Sealed Beam Type Headlamp Unit-RHD

SKU: 204E-13007-B

12v 65/55watt, RHD, with side light window, three spade terminal connection. LHD unit also available.



7" Quadopto Headlamp Kit-UK RHD Sidelight

SKU: S4698B

Supplied complete with dust cover and 12V bulbs-H4 P43t 60/55W and T10 WEDGE 5W sidelight.



5 3/4" Headlight Assembly, Dip & Main

SKU: 1314B

With or without a side (parking) light. A quick and easy conversion from old sealed beam units.



5 3/4" Domed Lens EURO/USA + Sidelight

SKU: LA1014

H4 Halogen fitting, plus BA9s sidelight bulb holder. UK RHD version also in stock.



5 3/4" Plastic Nest With Chrome Retainers

SKU: S5538

With nest to body gasket. Suitable for LA1014, LA1015, LA1016 and LA1017 and many other 5 3/4" light units.



7" Headlight Nest-Open Back

SKU: S5669

Used for pop up headlights or where rear space is limited. Includes nest to body gasket.



7" Metal Lucas Pattern Bowl-2 Adjuster Type

SKU: 357B

Metal Lucas type headlamp nest for standard 7" (700) light units. Two adjuster type.



7" Plastic Nest With Chrome Retainers

SKU: S5400

Direct replacement for the Lucas type metal nest and suits near all 7" light units.



H4 Headlamp Wiring Harness

SKU: 5825W

Made in house, BS specified wiring and wire colours. Approx length 45cm



Headlamp Rim Catch Painted Brass

SKU: 13016-D

Fits inside headlamp rim, tongue fits through rim slot which then accepts fixing screw. Many other types...



Headlamp stud, 5/8" x 26 tpi-late Lucas

SKU: 629A

Headlamp mounting bolt (hollow), thread 5/8" x 26 tpi (fine thread) as original. 56mm long



Headlamp W Wire-P100 Type

SKU: 642L

Large W wire for holding glass into rim, approx 54mm long side. Many other sizes and types



Headlamp Daisy Head Rim Screw-36mm

SKU: 641

Daisy head headlamp rim screw for Lucas L140 & L150 headlamps, overall length 36mm



7" Headlamp Rim Seal Gasket

SKU: 620

700 series headlamp glass to rim rubber dust gasket. Lucas part number 552906.

Lighting

Lucas PF770 Parts, Spot, Fog & Driving Lights

The Lucas PF770 was a premium 7.7inch headlamp with a tri-bar behind the glass. Fitted to Rolls-Royce, Bentley, Jaguar, Bristol, Aston Martin and Jowett.



Early PF770 Lamp Retaining Rim

SKU: A004

Chromed part to retain the light unit into the seating rim with the addition of the spring. Lucas No. 552686.



Late-PF770 Headlamp Backshell

SKU: A012

Late PF770 bowl as fitted to Rolls-Royce, Bentley, Jaguar XK140/150, Bristol, Aston Martin and Jowett.



Early PF770 Pivot Adjuster Kit

SKU: A006

Fixing Kit for Early PF770 Headlamps. Parts to allow the pivot adjustment of the lamp in relation to the backshell.



Late PF770 Adaptor Rim to fit 7" Light Units

SKU: A015AM

Part to retain the light unit into the seating plate when using 7" Light Units on Late PF770 seating plate.



Early PF770 Lamp Retaining Spring

SKU: A005

Retaining Spring to hold the lamp into the seating plate on Early PF770 Headlamps. Use with the retaining rim.



5 3/4" Stainless Steel Spot-light - 'Toby'

SKU: 1267SH1MED

Domed lens. Metal reflector without pilot bulb. E Marked. Accepts H1 Type bulb.



Classic Style 5 1/2" Chrome Fog Lamps

SKU: S6078

Classic 5 1/2" chrome fog lamps Pair complete with 55w bulbs & Plastic Covers.



Vintage Style Fog Light, Yellow Lens

SKU: C364007

Chrome With Universal Ball and Cup Mounting. Vintage Lens Pattern Design From the 1940's.



Reproduction SLR576-Base Mounted Spot

SKU: SLR576P

High quality reproduction of Lucas SLR576 type spot/driving lamp. Plain glass lens with chrome centre knob.



Reproduction SFT576-Base Mounted Fog

SKU: SFT576P

High quality reproduction of Lucas SFT576 type fog lamp. Block glass lens with chrome centre knob.



Small Chrome Spot Lamp (Pair)

SKU: D5933

12v H3-55w halogen bulb spot light can be fitted on a badge bar. 98mm x 92mm.



Lucas Square 8 Spot/Drive Lamp

SKU: LDB306

Lucas licensed reproduction of the Square 8 Spot Lamp. Approx. 180mm by 105mm



New Mini Driving Lamp (Pair) Stainless

SKU: S6066

BMW 'New Mini' Stainless Bodied Driving Lights. 55w Bulbs.



H1 Rear Search Light

SKU: H1RSL

Suitable for mounting on the rear of utility vehicles, Land Rovers etc.



6" Slim Stainless Steel Driving Lamps

SKU: S6015

6" Driving lamp 12V H3 lamps with stainless body and rim. 160mm diameter, 75mm deep. E Marked.



Raydyot Hs495 Type Pillar Mounted Spot

SKU: 570P

Chrome on brass to original HS495 pattern, with adjustable arm and handle.



Fog Lamp Equivalent Lucas Part No. Ft27

SKU: FT27

High quality British made reproduction of the FT27 auxiliary/fog lamp fitted to the MG TA, TB, early TC.



Lucas Square 8 Lamp Cover

SKU: LDB305COV

Replacement cover for the Lucas Square 8 fog or driving light



H1 Upgrade Kit For British Pre-Focus Spots

SKU: H1UPGRADE

Kit for traditional Spot, Fog or Driving lights, enabling use of modern H1 bulbs



New Mini Lamp Brackets (Pair)

SKU: S6070

Stainless brackets for the 'new Mini' driving lights. (Mk 1 R53)



Add indicator function to your vintage lamps

Now available with fitted LED light boards

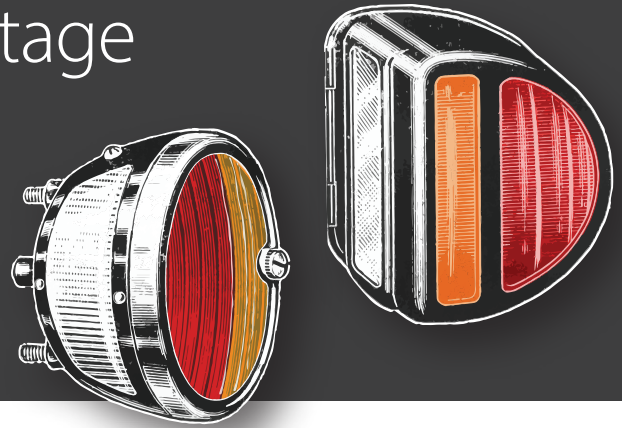

Round Rear LED Pork Pie Lamp

SKU: CA1249B-LED

Toby 'Pork-Pie' lamp (equivalent to Lucas ST38). High quality brass body with black or chrome finish. On-board electronics make this lamp suitable for 6v or 12v, positive or negative earth. Features a main, circular RED (dual brightness) and AMBER light board. An additional WHITE LED light board provides number plate illumination. Super bright, clear functions with very low power requirements.



Rear LED "D" Lamp

SKU: CA1149C-LED

Toby Split Lens "D" lamp (equivalent to Lucas ST51). High quality steel body with black or chrome finish. 6v or 12v, positive or negative earth. Super bright, plus good distinction between STOP and TAIL brightness. Very low power requirements.

i Add bright clear indicators to your vintage car without having to bolt on incorrect additional light units. Modern levels of brightness without overloading an old electrical system. LED brake lights illuminate much faster than traditional bulbs. If the car behind is travelling at 60 mph, that difference in illumination time is worth an extra 18ft of braking distance.



Black 'D' Lamp Split Red Glass Lens
SKU: 249A

Early pattern reproduction 'D' lamp with split red glass lens, fitted with two bulb holders.



Round Rear Lamp With Indicator Conversion
SKU: CA1249

Three single contact WEDGE T10 capless bulb holders. With or without side number plate window.



Duolamp Rear Lamp With Split Lens
SKU: 211

Polished stainless steel 97mm diameter x 51mm deep. Two single contact bulbholders.



STOP Script Tail Light All Red Lens
SKU: 211RBRSTOP

Gloss black powder coated housing and steel rim. High quality split glass lens with 'STOP' script.



LED Flasher Relay - 3 Pin Plus Earth Lead
SKU: LEDFLASH3

LED flasher relay. 12 volt. 3 pin. For vehicles that are changed in full or part to LED indicators/turn signals.

Lighting

Classic Rear Lights

Over 300 rear lights for classic and vintage applications. Many exclusive from SVC, the classic lighting specialist.



Black 'D' Lamp Full Red Glass Lens

SKU: 249

With double contact bulbholder (for stop and tail lamps) brass body 92mm x 85mm x 60mm.



Red 'Duolamp' Rear Lamp Stainless Rim

Sku: 958

Single red lens 'Duolamp'. Gloss black powder coated housing with polished stainless steel rim.



Tail Light Gloss Black + Stainless Rim

SKU: CA1264S

High quality all red glass lens with clear side lens for number plate illumination. Uses a BAY15D bulb



Rubber Lamp With Side Window As Rubbolite

SKU: 257-s

A neat rear lamp as Rubbolite number 25 lamp, with single mounting.



Rubber Lamp With Side Window As Rubbolite

SKU: 291

Round Rubbolite number 23 rear lamp, two double contact bulb holders fitted.



'Owl Eye' Rear Lamp as Type 312B

SKU: 901

A quality recreation of the original Lucas type 312B lamp. Chrome plated finish on brass pressings. Toby badge.



Toby Divers Helmet Lamp as CAV, Rotax, Lucas

Sku: CA1177

Superb lamps—available in polished brass, bright nickel or chrome finish. Choice of Red, Amber & Clear lens.



Rubber Bodied Light Stop & Tail (PAIR)

SKU: 1220R

Rubber body and bracket. Ideal for hiding on older cars. With Red lens for a stop or tail light. 48mm



L471 Type Rear lamp

SKU: 577

Reproduction angle mounted rear lamp equivalent to Lucas L471—Lucas 53200



L549 Type Rear lamp

SKU: 53330

Rear stop/rear reproduction L549 type lamp for mounting onto sloping rear wing panel. Red plastic lens.



L548 'Cathedral' Type Lamp Frame & Lenses

SKU: L548

Commonly fitted to Aston Martin DB4, Alvis TD21, Humber Hawk, and various Rolls-Royce and Bentley vehicles.



LED Teardrop Stop And Tail Light

Sku: A1060LED

1938-39 Ford Stop and Tail Light, originally for 1930s Ford. 28 Super Bright Red LEDs behind glass Lens.



Mini LED Stop & Tail Light (Pair)

SKU: BILED001ST

A small LED stop and tail light. Fully 'E' marked. The light output is very bright.



L542 Type Stop & Tail Light

SKU: L542

Superb reproduction of L542 lamp & reflector fitted to AC Cobra and Ace, Jensen 541 and Hillman Minx.



L691 Type Stop And Tail Light

SKU: L691ST

Double contact bulb. Rim 83 mm. 'E' Marked. Austin Healey, Hillman Imp, AC Cobra, Morgan.



Ring, LED Stop and Tail Light Red 95mm (pair)

SKU: RCV4500

95mm LED with Stop & Tail functions & Red Reflector. E Marked.



Stop & Tail Lamp for Land Rover

Sku: 300ST

Stop & tail lamp with 73mm outer diameter. Uses a BAY15D bulb.



L525 Type Lamp Stop, Tail & No. Plate

SKU: L525

Fitted to Triumph TR2 and TR3 as well as many motorcycles.



Rear Motorcycle Lamp- As Lucas Mt110

SKU: MT110

A good reproduction, used on motorcycles. Also useful for additional number plate illumination etc.



Equivalent to Lucas L582-Legal Lens

SKU: 288

Reproduction of a very popular vintage rear lamp type 582 with side number plate illumination & legal rear lens size

Lighting

Light Clusters, Reflectors, Number Plate Lights

Over 30 different types of rear reflector and a dozen number plate lights in stock to suit your classic or new build car. Some of the most popular items shown below.



Flat LED Light Cluster
SKU: LED322

LED Stop / Tail and Indicators lights are ideal for sports cars & trailers. 170mm x 92mm. 33mm deep.



LED Stop, Tail, Indicator Carbon Effect Housing
Sku: 322CE

Only available from SVC. These are about 700 grams lighter than the standard lights originally used by Caterham & Westfield.



L940 Type Mini Mk3 Rear Lamp
Sku: L940

Good high quality reproduction rear lamps, suitable equivalent for the Lucas L940



Rubber Reflector, as Lucas Type RER2
Sku: 240

Angled rubber red reflector, as Lucas type RER2, for mounting on to sloping rear wings etc. NOS and reproduction.



Early Pattern Reflector With Mounting Bracket
Sku: 179

Re-manufactured reflector (42mm diam)-aluminium spinning with black metal bracket.



Large Reflector-As Lucas Type RER14
SKU: RER14

Approx 71mm diameter overall. Single centre M5 screw fitting.



Deep Reflector-As Lucas Type RER25
SKU: 872

Approx 51mm diameter overall. Single centre screw fitting.



Rectangular Reflector-As Lucas Type RER22
SKU: RER22

As fitted to Triumph GT6, Austin Healey Sprite/MG Midget, & Morgan cars.



Amber Reflector Disc-40mm Diameter
SKU: AMBREF

40mm diameter, alternative to red disc, will fit our 394, 167, 872 and 240 reflectors..



Rectangular Self Adhesive Reflector
SKU: 0312R

Rectangular Self Adhesive 104mm x 51mm x 7mm..



550 Type Number Plate Lamp "Frogeye"
SKU: 550NP

Used on Triumphs & GT40 MK1 cars. Chrome on Brass Cover. 48mm x 35mm



Equivalent to Lucas Type L467
SKU: 708

Quality reproduction of the Lucas 467 lamp, as fitted to numerous vehicles.



Small LED No. Plate Light
SKU: SOL534

Universal screw fitting, 12v 0.2w 4 Bright LED's 56mm x 25 mm



LED Number Plate Light & Bracket
SKU: 533

A nice bright 3LED number plate light & mounting bracket 38mm x 10mm.



L860 Type Number Plate Light
SKU: L860

Used on Aston Martin, MG, Triumph etc. Mounting hole centres 58mm



Stainless Steel Light Bolt
SKU: 532

Ideal for a number of applications including dash lights 12.5mm Diameter x 14mm tall + thread



Land Rover LED Number Plate Lamp
SKU: LNL005LED

Solid ABS black plastic surround 50mm high, 111mm wide, 41mm deep



Small High Level LED Brake Light-Red Lens.
SKU: 1257SM

Fit inside or outside vehicle. Length approx. 140mm lens depth approx 30mm



Small High Level LED Brake Light-Clear.
SKU: 1257SM

Fit inside or outside vehicle. Length approx. 140mm lens depth approx 30mm



Clear (red light) LED High Level Brake Light
SKU: 1257C

Inside or Outside fitting, adjustable mounting 360mm x 18mm.

Lighting

Reverse, Fog, Indicators & Spare Parts

A comprehensive range of rear fog lights, reversing lights and indicator light units to suit vintage, classic and special or kit-car builds. A cross-section of the range is shown below.



**Rear Fog Lamp
Stainless**

SKU: 978R

Polished stainless steel (110mm x 55mm x 80mm deep) with polycarbonate lens. 20w halogen bulb



**Rear Reversing Lamp
Stainless**

SKU: 978C

Polished stainless steel (110mm x 55mm x 80mm deep) with polycarbonate lens. 20w halogen bulb



**Rear Reversing & Fog
Lamps**

SKU: WEST

As used by Westfield & Caterham Cars. 120mm x 80mm. 2 stud fitting at rear



**Rear Fog & Reversing
Lights**

SKU: HELFGL/HELRLV

A competitively priced and good quality light made in Finland. Lens 140mm x 65mm.



**SVC Fog & Reversing
Lights**

SKU: SVCFG / SVCRV

85x73mm Compact sized and very popular lights. Bracket or rear mount.



**Pedestal Indicator Long
or Short Stem**

SKU: 874PED

Equivalent to Lucas type L874 Chrome pedestal indicator lamp 120mm or 80mm stem.



**Small Chrome Indicator
Lamp**

SKU: 932

Body approx 58mm x 70mm long. Single mounting stud. Uses a BA15s bulb.



**Wing Top Indicators
(pair)**

SKU: INDFBLK

Wing Top Indicators clear or smoked lens-black body or carbon effect. 90 x 50mm.



**Arrowhead Indicator-
Mini Indicators Pair**

SKU: 6415

Feature a cut-out on the reverse side which allows the indicator beam to be visible from the front & back



**Indicator Equivalent to
Lucas L594**

SKU: 993

Flush back indicator lamp approx 72mm rubber back, stainless steel rim with plastic or glass lens.



**Indicator Side Repeater
Lights**

SKU: L734

Equivalent to Lucas L734 type with Chrome Base. 79mm x 24mm and 24mm high. Rubber gasket



**Rubber Bodied
Indicator & Bracket**

SKU: 1220A

Ideal for unobtrusively fitting on older cars. With Amber lens for Indicator. 48mm diameter.



**Indicator Lamp Equivalent
to Lucas Type 582**

SKU: 288AB-IND

Early pattern lamp with amber prismatic lens and screw on rim. 45mm diam.



**Pedestal Indicator
Bracket for MG TD**

SKU: 875B

Pair of stainless brackets for Pedestal Indicators when fitted onto a MG TD



**Small Indicator Lamp
with Amber Lens**

SKU: CA1293A

Very small chrome warning/indicator lamp with amber lens. (40mm x 25mm x 40mm depth)



Replacement Lenses

Over 70 types of replacement lenses in glass & plastic



**Replacement Rims &
Catches**

Spare rims, catches & grills in chrome, stainless & plastic for front & rear light units.



**Replacement Boots,
Seals & Gaskets**

Rubber, foam & cork seals and gaskets to keep your lights watertight.



**Various LED Conversion
Kits for Classic Lights**

Add functions and improve light output. High quality lens and sealed electronics.



**Replacement Lamp
Badge Medallions**

Reproduction Desmo, Rotax, Raydot and Red Dots for your vintage lamps

Metal Pipe & Fittings

Unions, Nuts, Olives, Plugs & Tees

A full range of metal fittings to allow you to plumb fluid systems in copper, or to finish/incorporate flexible hoses and fittings listed elsewhere on this site. The range includes brass banjos, unions, tees, elbows, solder nuts and nipples, flanged plugs, compression nuts and olives, hose tail fittings, crimping ferrules, copper and stainless tube.



Banjo Union and Fittings

SKU: Various

Solder or compression fittings to metal pipe. Multiple sizes and threads. With bolt & washers.



Copper & Stainless Steel Tubes

SKU: Various

Malleable copper pipe and seamless stainless 316 pipe in multiple sizes. Per metre



Crimping Ferrules for flexible pipework

SKU: Various

Brass & zinc passivated mild steel. Swaging tools required to crimp these ferrules on to hose ends. Assembly service available.



Brass Elbow Joints for Pipework

SKU: Various

Brass BSP elbows with various sized connections & options complete with solder fittings.



Nuts & Olives

SKU: Various

Brass nuts and copper olives for solderless compression joints and fittings



Brass Drain Plugs

SKU: Various

Hex headed, flanged brass drain plugs. 8 sizes & threads



Solder Nuts & Nipples

SKU: Various

From 1/8" to 1/2" BSP and 1/8" to 1/2" copper pipe. The range also includes fittings for oil pressure gauges, with a flat faced nipple & fibre washer



Brass Tee Connections

SKU: Various

Range of brass Tees with male or female threads or complete with either compression or solder fittings for a range of sizes.



Unions

SKU: Various

Brass double ended unions. Equal & unequal male threaded unions, some with solder fittings for copper pipe.

100's of Imperial brass fittings in stock for quick delivery



VINTAGE SUPPLIES

www.vintagecarparts.co.uk

Looking for more parts for your vintage or veteran car?

The leading specialist manufacturer and supplier of parts, and fittings for the restoration and maintenance of vintage and classic vehicles.

- Quality Coachfittings
- Body Parts
- Trimming and Upholstery
- Cloths and Beadings
- Rubber Mouldings
- Electrical, Switches and Cable
- Lamps
- Wipers
- Period style re-manufactured accessories

Mirrors

Classic, Exterior

As well as lighting, SVC has always been known for it's huge range of mirrors. Vintage, classic and modern styles—wing, door, screen and dash mounted, Here is a sample across the ranges in stock.



Clip-on Mirror
SKU: 981

Gutter mount clamp on mirror. Convex glass 115mm x 73mm with stainless steel back



Rectangular Long Arm Clip-on Mirror
SKU: C5003

Designed to fit on the front edge of a door, 64mm x 127mm Stainless Steel Mirror Head, Cast Arm.



3" Straight Arm Clip-on Mirror
SKU: A4007

3" polished stainless steel head designed to fit on the front edge of a door, mounting arm 143mm long.



Quarterlight Clip-on round mirror small
SKU: MIR040

Stainless bracket and mirror back, 78mm flat glass. Can be fitted to 1/4 light frame, or pillar gutter.



Clip-on Circular Peep Mirror 3 inch
SKU: CA1377

Fit to left or right side of vehicle. Head approx 78mm diameter, stainless steel back with flat glass.



Tex Door Bullet Mirror-Right Hand
SKU: TEXBUL-R

Universal fitment for door mounting as on early Minis and other classics



California Mirror Black
SKU: CALMIR

Vitaloni California mirror as used on the Lancia Stratos, size 160mm x 100mm.



Classic Type Door Mount Rear View Mirror
SKU: CA1403

Superb classic mirror that screws to a mounting plate that you attach to your door. Typical 1960's & 1970's



Oval Mirror With Jointed Arm
SKU: CA1262

Fine reproduction of this very popular mirror (size 110mm x 82mm) fitted with a convex glass



Door/Wing Mirror Stainless Steel
SKU: MIR314

Chrome stem which is suitable for door or wing mounting, 120mm diameter head fitted with flat glass,



Rear View Mirror Wing Mounting
SKU: 782

Chrome plated 100mm diameter, aerodynamically styled, fully adjustable and vibration free



Polished Stainless Steel Racing/Bullet Mirror
SKU: MIR318

Polished stainless racing/bullet reproduction of the "Raydyot" model, popular for Cobras and many racing cars.



Lightweight Alloy Racing Mirror
SKU: MIR317

Lightweight reproduction of the "Raydyot" model, popular for Cobras and many racing cars.



Rear View Mirror-Black Alloy
SKU: CA1464

Rounded lightweight black finish alloy racing mirror with rim, 100mm diam, single bolt fixing, flat glass.



Lightweight Alloy Bullet Mirror
SKU: MIR319M

Lightweight, 90mm glass. Because of the matt finish this mirror can be painted to match the body colour.



Vitaloni Sebring Mirror Chrome
SKU: SEB-chrome

Can be mounted on the wing or on a raised platform, as on the original SCCA spec racer design



Wing Mounted Mirror Equivalent to Lucas 406
SKU: 651

Early mirror that remained extremely popular for many years. 106mm diameter, stainless steel back.



Swing Back Mirror Adjustable Arm
SKU: 379

Stainless steel head, convex glass, chrome stem. Multiple variations of arm. Head available separately.



'USA' Style Mirror with 406 Type Head
SKU: MIR312

American style similar to MIR310 but fitted with a 406 style head that offers much more adjustment.



Swing back mirror, Tapered Head
SKU: 381

Tapered shape, 113mm x 102mm stainless steel head (convex glass), chrome stem 16mm hole in panel

Mirrors

Interior and Accessories



MGB Rear View Mirror-Gold Backed

SKU: MGBGLD

To fit on the centre strut on early MGB's. Can also be used on E Types and some Cobras.



Rod Mount Interior Mirror-Stainless

SKU: 941BJR

Clamps to rod of max 5mm diameter 155mm x 61mm with flat glass. Chrome on brass clamp



Polished Stainless Steel Oval Mirror Head

SKU: MIR942-OS

144mm x 70mm head with single stud mounting to fit directly into an arm (not supplied).



Interior Rear View Mirror

SKU: MIR942-OH

Polished stainless, flat glass with swan neck chrome arm, mirror head measures 118mm x 54mm



Dash Mounted Interior Rear View Mirror

SKU: 584

Wingard pattern mirror, 2 screw base fitting, flat glass mirror 148mm x 60mm



Dash mounted mirror-XK120 type

SKU: CA1277

Chrome mirror (original application Jaguar XK120). flat glass (NO protected edge). Long & Short arms



Desmo Type 300 Rear View Mirror

SKU: 891

Vintage pre-war pattern, convex glass 100mm x 42mm, top or bottom fixing. Chrome or Nickel finish.



Classic Mini Interior Mirror Stainless

SKU: MIR859

Clamps to windscreen surround with a substantial chrome on brass swan neck bracket- flat glass.



Wingard 693a Interior Mirror

SKU: 693A

Original new/old stock Wingard 693A. Flat glass (105mm x 42mm) Black crackle finish frame.



Interior Rear View Mirror-Stainless

SKU: CA1263

Stainless steel with chrome stem as fitted to MGA etc. flat glass, head approx 130mm x 57mm



'Toby' Mirror Equivalent to Lucas Type 150

SKU: 806LT

Hand spun brass round mirror head 145mm diameter. Reproduction of the Lucas 150 model.



Round Rear View Mirror Brass or Chrome

SKU: CA757

Suitable for the smaller Edwardian car, flat type arm clamps to windscreen frame-(approx 25mm).



Spare Wheel Mount Rear View Mirror

SKU: 917

Brass construction, 120mm or 145mm diameter, flat or convex round head, leather straps. Polished brass, chrome or nickel plate.



'Toby' Veteran Rectangular Mirror

SKU: CA1013

Heavy Edwardian pattern mirror. Substantial arm approx 270mm long with secure mounting base.



'Toby' Type 160 Rear View Mirror

SKU: 395

Equivalent to the original Lucas Type 160, Original equipment for many '30s vehicles including MG and Bentley.



Mirror Mounting Arm Chrome, Brass or Nickel

SKU: 514ARM

Adjustable 1/2" (12mm) cranked rod arm, base 59mm x 22mm. Approx 190mm long.



Chrome Swing Back Mirror Arms

SKU: MIRROR-ARM

Chrome mirror arm, mounts through 16mm hole in panel, with swing back spring under arm. Various designs.



Triangular Mirror Mounting Bracket

SKU: 514L

Original style mount used on some MGs. Flat base plate 95mm x 15mm with 75mm hole centres.



Replacement Mirror Glass

SKU: 395G

Replacement convex mirror glass for Lucas type 160 (our 395) mirrors. 152mm x 75mm.



Mirror Rubber Base Gasket

SKU: 651G

Wing mirror (our 651) base gasket, tear drop shape 42mm long x 32mm wide with a 10mm hole.

OBP Tanks

Oil Catch Tanks, Fuel Swirl Pots & Header Tanks

Top quality OBP British made aluminium products. Ideal for use on all types of cars from track day specials to many classics. A sample of sizes and shapes available.



Coolant Header Tank, Horizontal Round

SKU:OBPHE001

This is ideal for all types of car, it is made out of 2mm alloy and is very light. It can be polished up to gleam under the bonnet of your show car, or to be used in a light weight race car. This unit is designed to fit to a bulk head or other flat surface

Size: 200mm x 100mm. Standard Radiator Cap Top, 18mm In, 10mm Out, 8 mm Over Flow Pipe (NO CAP)



1ltr Round Oil Catch Tank, Bulk Head Mount

SKU:OBPCT004

An Oil catch tank is a must have for race cars / track cars and turbo applications. This 1-litre oil catch tank does exactly what it says it does, it still allows the engine to vent the hot oily vapour, but it catches it inside the tank, and then vents the clean air to the atmosphere. Drain Bung, Sight Tube

13mm Inlet, Outlet & Breather.
Size: 180mm x 90mm x 90mm



2ltr Square Oil Catch Tank, Bulk Head Mount

SKU:OBPCT002

An Oil catch tank is a must-have for race cars / track cars and turbo applications. This 2-litre rectangular oil catch tank does exactly what it says it does, it still allows the engine to vent the hot oily vapour, but it catches it inside the tank, and then vents the clean air to the atmosphere. Drain Bung, Sight Tube

13mm Inlet, Outlet & Breather.
Size: 200mm x 150mm x 70mm



2 Ltr Fuel Swirl Pot, Bulk Head Mount

SKU:OBPA022

2 Litre fuel swirl pot for the serious motorsports enthusiast who is using a fuel-injected car for competition or fast road use. Benefits of a Swirl Pot: Reduces injection pump failure. Controls a supply of constant fuel. Will not starve the engine of fuel whilst hard cornering.

Size: Bulk Head Mount 100mm Dia x 280mm 2 Ltr Fuel Swirl Pot, 4 x 10mm Outlet / Inlet pipes.



1.5 Gallon Dry Sump Oil Tank

SKU:OBPDS02

Because a dry sump does not need to have an oil pan big enough to hold the oil under the engine, the main mass of the engine can be placed lower in the vehicle. This helps lower the centre of gravity and can also help aerodynamics.

Size: (D)190mm x (H)355mm, 2 x JIC 8, 1 x 10mm Breather, 40mm Screw Cap Filler



Coolant Header Tank, Vertical Round

SKU:OBPHE002

This is ideal for all types of car, it is made out of 2mm Alloy and is very light. It can be polished up to gleam under the bonnet of your show car, or to be used in a light weight race car. This unit is designed to fit to a bulk head or other flat surface.

Size: 200mm x 100mm. Standard Radiator Cap Top, 18mm In, 10mm Out, 8 mm Over Flow Pipe (NO CAP)

Oil System & Lubrication

Oil Cooler Kits

SVC stock a vast range of oil system components from oil, filters, grease and application parts to help you service and maintain your vehicle—through to oil filter adaptor kits, filter relocation components and complete cooling system kits.



Oil Cooler Kits for Classic Cars

Complete systems for over 50 classic cars – some will require fitting of an Oil Filter Adaptor Kit to enable installation and this is indicated in the product description where applicable. Kits feature take off plates, Setrab coolers, rubber lined P clips, adaptor fittings, appropriate PUSH ON hose fittings and the required length of Rapide hose. Hose bore is 1/2" as standard, increased to 5/8" for large capacity engines and where oil flow is known to be restricted. Similarly most systems feature a 10 row full width cooler, upgraded to 13 row where required. Many systems feature a thermostatic take off plate as standard, though non-thermostatic plate systems can be provided at lower cost—for racing, summer use only and warm climates. If your vehicle isn't listed below, please call for advice on configuring a system.

Item ID	Vehicle Application for Oil Cooler Kit
OCENQ	Generic Oil Cooler System- contact for assistance
OCH2	Healey Sprite and MG Midget pre 1974
OCH1	Healey 100-6 and 3000
OCF7	Ford Anglia, Escort and Cortina, pre 1971, with original oil filter
OCF8	Ford Anglia, Escort and Cortina, pre 1971, with spin-off filter
OCF11	Ford Escort 1300 and 1600 OHV Post 1971- with spin off oil filter
OCF4	Ford V4 and V6 Essex engine without PAS—with spin-on oil filter
OCF3	Ford V4 and V6 Essex engine with PAS—with spin off oil filter
OCF2	Ford V4 and V6 Cologne engine—with spin off oil filter
OCF9	Ford Capri 2.8 Litre—with spin off oil filter
OCF6	Ford Escort XR3i—with spin off oil filter
OCF1	Ford RS2000—with spin off oil filter
OCF5	Ford Sierra Cosworth—with spin off oil filter
OCJ6	Jaguar XK120/140
OCJ4	Jaguar XK150
OCJ3	Jaguar MkII
OCJ5	Jaguar E-Type 3.8
OCJ1	Jaguar E-type 4.2 S1
OCL1	Lotus—All models pre 1971—pre 1970 Ford Engines
OCL2	Lotus Eclat, Elan to 1975, Europa and Excel—post '71 with spin off oil filter
OCMG1	MG Late TC and Early TD—hoses, adaptors and cooler
OCMOG2	Morgan 4/4 1600 1968 to 1993—with spin off oil filter
OCR1	Reliant Scimitar 3 Ltr Essex Engine 1968 to 1975—with spin off oil filter
OCS1	Saab 99 2 Ltr—with spin off oil filter
OCT1	Triumph Herald and Spitfire—with spin off oil filter
OCT10	Triumph TR7 to 1982, Stag to 1977 and Dolomite Sprint to 1981
OCT4	Triumph TR2/3/4a—in line fitting with original oil filtration assembly
OCT5	Triumph TR2/3/4a—for use with a spin off Oil Filter Adaptor Kit
OCT6	Triumph TR5 and 6—in line fitting with original oil filtration assembly
OCT7	Triumph TR5 and TR6—90 deg fitting with conversion to spin off filter
OCT11	Triumph 2000 and 2.5 PI- 90 deg fitting with conversion to spin off filter
OCT2	Triumph Vitesse and GT6 RHD—in line fitting with original oil filtration assembly
OCT3	Triumph Vitesse and GT6 RHD—90 deg fitting with conversion to spin off filter
OCT8	Triumph GT6 LHD—90 deg fitting with conversion to spin off filter
OCV2	Vauxhall Chevette, Viva, Firenza, Magnum OHC (T)—with spin off oil filter

Oil System & Lubrication

Oil Filter Adapter Kits

Oil Filter Adaptor Kits for Classic Cars

SVC now supply Flexolite oil filter adaptor kits for a wide range of classics. The kits enable vehicles with older filter systems to utilise modern spin-off oil filters. All Flexolite adaptor kits are easy to fit and make changing the oil filter a clean and simple operation. The adaptors should not affect oil pressure switches, warning lights, or pressure-relief valves. In many cases they will provide improved start-up oil pressure due to the use of anti-drain valves in many modern spin-off oil filters—and all cars will benefit from the improved filtration capability of modern filters. Fitting a Flexolite oil filter adaptor also makes it easy to fit an oil cooling system to your classic – vital for competition cars as well as older cars needing to keep pace with modern motoring conditions. Kits come complete with instructions, any gaskets or seals required, and one filter. Many British cars of the 1950s and '60s shared engines, so if your model is not listed please look at other marques which used the same engine. Note that vehicles with by-pass filters can use a conversion kit with a remote filter head that takes a modern spin-on filter—please contact us for advice. FINALLY- please check the inner and outer ring adaptor plate dimensions in the product description on our website against your filter head – as this is the best indication (other than matching Fram or Tecalemit filter head numbers) that the kit is right.



Generic Image—kit varies according to vehicle

Item ID	Application for Oil Filter Adapter Kit
FA001	Ace/Aceca to 1963—AC Engine
FA021	Ace—Bristol 6 Cylinder Engine
FA113	Alfa Romeo 105 Series—filter heads marked 'Comit'
FA002	Alfa Romeo 105 Series to 1974
FA003	Alfa Romeo 1900 to 1963
FA008	Aston Martin 6 Cylinder Engine to 1963
FA011	Austin A35
FA097	Austin A90 Westminster to 1959
FA031	Austin A90 Atlantic
FA032	Austin A110
FA031	Austin A123/A135
FA115	Austin Healey Sprite (Tecalemit FA2717)
FA119	Austin Healey Sprite (Purolator)
FA015	Austin Healey 100/4 to 1956
FA016	Austin Healey 100/6 to 1959
FA017	Austin Healey 3000 to 1968
FA081	Austin Healey 3000 Horizontal conversion
FA018	Bentley MKVI 4.5 Litre to February 1952
FA019	Bentley Continental, R Continental and R-Type 4.5
FA020	Bentley Series I to 1959
FA107	Bristol 406—110 Engine
FA025	Daimler SP250/Dart to 1969
FA026	Daimler V8 250 to 1969—screw in to filter head
FA133	Ford 8 and 10HP 1933 to 1959
FA088	Ford 100E to 1962
FA083	Ford 105E
FA090	Ford Consul, Zephyr Zodiac Mk II and III 1956 to 1966
FA028	Hillman Imp
FA035	Jaguar Mk 1 and 2 Early
FA036	Jaguar late Mk 2, 240, 340
FA033	Jaguar MK V (bolt down) to 1951
FA080	Jaguar Mk VII (Engine no A1001—B5304)
FA077	Jaguar XK120 (Engine Number W1001 to W4382)
FA078	Jaguar XK120 (W4383 on), XK140 and Mk VII
FA079	Jaguar XK140 (G6233 on), Mk VI, Mk VIII & IX

Item ID	Application for Oil Filter Adapter Kit
FA034	Jaguar XK150 to 1960
FA037	Jaguar E-Type 3.8
FA038	Jaguar E-Type 4.2 S1 1961 to 1968
FA039	Jaguar E-Type 4.2 S2 1968 to 1971
FA040	Jaguar S Type, 420, 420G and Mk X to 1969
FA041	Jaguar XJ6 S1 to 1973
FA042	Jaguar XJ6 S2 to 1978
FA075	Jowett Jupiter (early cars with Vokes filter head)
FA043	Jowett Javelin and Jupiter to 1954
FA044	Lancia Aurelia B20 Series 4 to 6 and B24
FA046	Lancia Flaminia
FA106	Land Rover Series I—1948 to 1958
FA118	Land Rover Series II
FA049	Lotus Elite to 1963
FA135	MGA, MGB to 1967—18G, GA, GB engines
FA012	MGA/MGB to 1970—NOT 1500
FA014	MGC Series to 1969
FA050	MG TD, TF to 1955 & YA, YB late, XPAG to 1953
FA122	MG Midget to 1970
FA053	Morgan Plus 4 (TR3 engine) to 1969
FA124	Morris Oxford to 1971 (NOT 1500)
FA123	Morris Minor to 1971
FA101	Porsche 356
FA121	Reliant Sabre (with Ford Mk2/3 Zephyr straight 6)
FA058	Rover P4—(Bolt up through filter)
FA059	Rover P4—(Bolt down into filter bowl)
FA063	Triumph Roadster to 1949 with Fram FF21003 plate
FA065	Triumph Roadster to 1949 with Purolator filter head
FA066	Triumph TR2, 3, 4 and 4A to 1967
FA136	Triumph 6 cylinder—2000/2.5 Pl, GT6 & Vitesse
FA067	Triumph TR7 to 1982, Stag to 1977, Dolomite Sprint
FA068	Vauxhall Velox, Wyvern, early Cresta Series E to 1957
FA069	Vauxhall Cresta to 1972 and Victor FB to 1964
FA070	Vauxhall Viva to 1978 and Chevette to 1984
FA071	Volvo PV444, 544 to 1961

Oil System & Lubrication

Oil Coolers & Parts, Oil Filters



Oil Coolers

SKU: OCF & OCH



10 Sizes of oil cooler in stock.

SVC supply Setrab oil coolers due to their excellent reputation for quality and reliability. Our standard products are from Setrab's ProLine STD range—rugged and reliable oil coolers for all types of cooling on a vehicle; engine oil, transmission oil, clutch, brakes, differential and power steering. ProLine STD coolers are offered in full and half width. Proline SLM coolers are available special order. Our Setrab coolers are aluminium alloy construction with a working pressure of 10 bar(g) and a working temperature range of -40 to 150 oC. We offer a range of specifically designed adaptor fittings (part numbers prefixed OCA) for connection to BSP and JIC hose systems, as well as a range of oil cooler mounting kits from basic to Setrab specific systems



12V Oil Cooling Diaphragm Pump

SKU: EOP1

Integral cooling fan. Ports are 3/8" NPTF and may be rotated in 90° increments to simplify plumbing.



Oil Cooler Adaptor Fittings

SKU: OCA

M22 to various JIC & BSP threads. Specifically designed for the Setrab Proline Oil Cooler.



Oil Cooler Mounting Brackets

SKU: OCB

Basic kits, universal types and Setrab specific brackets and screw kits.



Adaptor Fittings

A vast range of adaptors. Most of our standard range are steel or brass, but aluminium fittings can be provided in most cases if required. Our range of fittings include male/male, female/male, female/female, elbow and bulkhead adaptors – converting between JIC, NPTF, BSP, BSPT, UNF and Metric.



Oil Filters

SKU: FF

SVC's oil filter range is listed with key dimension information as well as details of diaphragm, anti-drain and relief valve functionality where applicable. Relief valves are situated on the bottom end cap of the filter element inside the metallic housing and ensure release of overpressure that could be created from cold starts (high oil viscosity due to low temperatures). Another reason for relief valve operation is contamination of the filter media from dirt due to late service intervals. Anti-drain valves/rubber diaphragms ensure that filter remain full with oil – so readily available once the engine re-starts.

Search our database by vehicle, or with an Alco, Fram, T.J, Tecalemit, Mann, Crosland, Wix or AC etc. part number to identify an equivalent – checking filter type, dimensions and functionality offered match your existing filter. If your particular application is not covered by our current range, please email with details of your requirement – including any cross reference and key information—and we will investigate availability of an equivalent filter.



Oil Coolers

As well as performance and kit cars, many classic cars can benefit from an oil cooler to help cope with modern traffic conditions, especially on long motorway journeys, when engines tend to run at high speeds for long periods. This causes the oil to thin and a reduction in pressure may occur. The fitting of an oil cooler can help prevent the thinning of the oil and prevent possible engine damage.

Oil-tight Connections

Remember if you are not sealing on a cone (e.g. an adaptor into a remote filter head) you may require bonded seals or copper washers to make a seal.

If you cannot find the fitting you require, then please get in touch as we have access to a huge range of fittings via our network of suppliers.

For assistance with thread identification—please see the 'Help and Instructions' section online.

Oil System & Lubrication

Oil Hose, Hosetails, Remote Filter Heads,

SVC recommend 'Rapide' Hose for automotive oil systems (also suitable for fuel, air and coolant) and supply four bore sizes— $\frac{1}{4}$ ", $\frac{3}{8}$ ", $\frac{1}{2}$ " and $\frac{5}{8}$ ". Rapide hose is made from synthetic rubber with an inner textile reinforcing braid and has a working temperature range of -40 to $+120^{\circ}\text{C}$ and maximum working pressure of 400 psi.



Black Push-on 'Rapide' Oil Hose

SKU: R4, R6, R8, R10

Reinforced synthetic rubber
The simplest and most cost effective oil pipe work solution available.



Push-on Hose Fittings Straight-Hosetails

SKU: Various

Swivel and fixed female fitting to push-on hose connection. Multiple sizes and threads.



Push-on Hose 90° Fittings

SKU: Various

Swivel female fitting to push-on hose connection. Multiple sizes and threads.



Push-on Hose 45° Fittings

SKU: Various

Swivel female fitting to push-on hose connection. Multiple sizes and threads.



Assembly Lube for Synthetic Hose

SKU: HoseLube

Specifically formulated to ease the installation of hose ends onto synthetic rubber hose.



Planning your oil filter system

When planning the filter plumbing remember that oil nearly always flows down the outside of the filter and returns up the middle.

For all four hose bore sizes we offer two end fitting systems –

PUSH ON fittings give a working pressure of 250 PSI with easy DIY assembly, without the need for clips or special tools.

SWAGE or CLIP fittings requiring swaging or O Clips/worm drive clamps for DIY assembly. SVC can arrange for manufacture of custom swaged hoses or supply swaging parts if you have access to swaging equipment.

We can also provide quotations from old hose patterns you may have. Please enquire regarding prices of our swaged hose services.

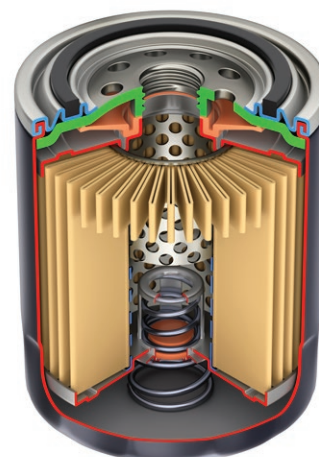

Example only—multiple designs



Remote Filter Heads

SKU: Various

Remote filter heads enable relocation of the oil filter where required. This may be due to lack of space, in a kit car or improving oil filtration on an older vehicle.

They are often used in conjunction with a take-off plate (which replaces the original filter) that can feed an oil cooler system, with or without a thermostatic element included.

In-Line Oil Thermostat

SKU: ILT2

Cast alloy in-line thermostat. Supplied with mounting bracket.

Thermostat fully open at 80°C .

- $\frac{1}{2}$ " BSP female connections
- $\frac{1}{2}$ " BSP male connections
- $\frac{3}{8}$ " BSP male connections
- M22 x 1.5 female connections
- Dash 10 JIC male fittings
- Dash 8 JIC male fittings

In-Line Oil Thermostat

SKU: ILT3

Lightweight, cast/machined alloy in-line thermostat. Spigots for push-on hose fitting
Thermostat fully open at 80°C .

- $\frac{3}{8}$ " Spigots for push-on hose
- $\frac{1}{2}$ " Spigots for push-on hose

Oil System & Lubrication

Grease Guns & Grease Nipples

A selection of our grease guns, accessories and grease nipple adaptors—push on, pull on and angled type for TAT nipples and standard 4 Jaw couplers for hydraulic nipples. Other lubrication accessories including lube injectors for bearings and seals, extension tubes, adaptor fittings and specialist connectors.



Grease Gun
SKU: 942

Side lever grease gun with rigid & flexible standard connector—for 400g cartridges or 500g bulk fill.



Professional Grease Gun
SKU: 942P

Top of the range side lever grease gun with precision 4 jaw connector. Short stroke delivery system.



Push Type Grease Applicator
SKU: 942-push

Push type grease applicator, supplied as shown. Body measures 165mm x 41mm, overall 215mm long.



Leaf Spring Greasing Tool
SKU: 937G

High quality reproduction of a useful period tool. Drive the wedge front section between the leaves of the spring to lubricate.



Extension Tubes & Flexible Hose
SKU: 937C/937D/927E

1/8" BSP straight & cranked extension tubes & hose for grease guns.



Lubrication Injector
SKU: 108F

For injection of oil or grease e.g. into bearings or seals. For connection to a 4 jaw hydraulic coupler e.g. our part no. 108D and 108E



Grease Gun Adaptor—Push On Or Pull On
SKU: 108A/108B

Adaptor for flat top grease nipples (TAT type). 1/8" BSP female thread which will fit most grease guns.



Grease Gun Adaptor—Adjustable Angle
SKU: 108C

Adaptor for flat top grease nipples (TAT type). 1/8" BSP female thread which will fit most grease guns.



Rotary connector
1/8" BSP
SKU: 937F

Recommended when using flexible tubes—fitted between the grease gun and the hose, the swivel action prevents kinking.



4 Jaw Couplers Precision & Standard
SKU: 108D/108E

15mm hexagon. 1/8" BSP connection for hydraulic grease nipples. Professional quality or standard.



Replacement Grease Nipple Caps
SKU: 841CAP

Packs of 10. Plain or with retaining straps



Bayonet Type Grease Nipple 1/8" Bsp Thread
SKU: 840

Bayonet style grease nipple found on some older vehicles. Zinc plated steel. 1/8" BSP male threaded connection.



Adaptor For Bayonet Style Nipples.
SKU: 108K

Grease gun adaptor for bayonet style grease nipples found on some older vehicles. 1/8" BSP female threaded connection



Conical Connector For Damaged Nipples
SKU: 108J

For damaged nipples of all types. Pointed end is used to deflect the ball in the grease nipple thereby permitting the injection of grease.



Connector For Concave Grease Nipples
SKU: 108H

Lubrication connector for concave grease nipples. 1/8" BSP thread.



Flat Top Grease Nipple TAT Type
SKU: Various

Multiple thread sizes, angles and lengths. Brass.



Straight Hydraulic Grease Nipple
SKU: 841STR

8 thread sizes available. BZP plated steel



45° Hydraulic Grease Nipple
SKU: 841ANG

7 thread sizes available. BZP plated steel



90° Hydraulic Grease Nipple
SKU: 841RIGHT

6 thread sizes available. BZP plated steel



Enots Type Grease Nipple & Cap
SKU: 204/205 & 206

Enots type grease/oil nipple, 5/16" or 1/8" BSF thread, nickel plated. Screw on cap available separately.

Oil System & Lubrication

Oilers, Oil Cans & Grease

Brass screw down cup greasers with a choice of threads, a range of oilers including straight, angled, flip top and Winkley (rotating sleeve) pattern. Most oilers are offered in a nickel finish only.



Cup Greaser—Screw Down

SKU: 310 to 316

Brass screw down cup greaser, Stauffer & RC type



Cup Greaser Type RC5— $\frac{1}{8}$ " BSP

SKU: 313

Brass screw down cup greaser, type RC5, cap size 28mm diameter x 17mm deep. NO clicker action.



90° Cup Oiler Flip Top $\frac{1}{4}$ " BSF

SKU: 939

Small angled flip top oiler, $\frac{1}{4}$ " BSF thread.



Cup Oiler Flip Top $\frac{1}{8}$ " BSP

SKU: 323

Flip top flap oiler, nickel plate finish, 7/16 hexagon, $\frac{1}{8}$ " BSP thread.



Winkley Pattern Oiler Rotating Sleeve

SKU: Various

These are usually fitted horizontally and the outer sleeve turns to cover the oil hole. 5 sizes/threads.



Premium Oil Can—500ml

SKU: 942CAN2

Aluminium oil can, newly developed swivel double pump mechanism, making oiling in every position possible.



Large Brass Oil Syringe With Long Spout

SKU: CA854

An invaluable tool for anyone whose car has an awkward-to-get-at gearbox or rear axle filler. 40mm diameter x 340mm long.



Castrol Pouring Jug—1 Pint

SKU: CJUG-P

Castrol Pouring Jug—For accurate measurement of lubricants as shown in your vehicle handbook. One Pint



Castrol Pouring Jug—Quart

SKU: CJUG-Q

For accurate measurement of lubricants as shown in your vehicle handbook. One Quart



Classic Red Pump Oil Can

SKU: 942CAN1

Steel bodied, all metal pump mechanism, supplied with rigid and flexible spout, 500cc capacity, 120mm tall, 85mm diameter.



Castrol Pump Oil Can—500ml

SKU: COIL500

The classic Castrol oil applicator. Pump action screw top can, with exchangeable fixed or flexible applicator.



Classic Castrol Enamelled Mug

SKU: CASTROLMUG

Perfect for internal lubrication when working on your car, or to hold those important fixings that you don't want to lose.



Oil Measure Can 2 Litres

SKU: 456-2LTR

High quality Tin Plate oil measure, very stable with anti surge top and funnel shaped spout. Dimensions 280mm tall.



Funnel With Mesh Strainer

SKU: 456-Funnel

High quality Tin Plate funnel with 0.7mm strainer, with handle and removable straight nozzle, strainer held with a spring ring



Castrol Spherol L/EPO Grease 500g

SKU: L/EPO

Lithium semi-fluid self-leveling grease for veteran and vintage cars and motorcycles, with grease packed axles/gearboxes.



Castrol Spherol SX2 Grease—400g

SKU: SX2

For use on wire wheel splines, exposed brake shoe pivots, handbrake mechanisms, gear linkages.



Castrol Molybdenum Grease—400g

SKU: MOLYMG

Suited for king pins and bushes, shackles and suspension trunnions, bevel worm & peg steering boxes.



Castrol High Temperature Grease

SKU: HTG

Extremely high melting point, lithium based grease, designed for use in anti-friction bearings.



Castrol Water Pump Grease—500g

SKU: WPG

Hard consistency grease for vane and gland type water pumps. Mostly for pre-1940 automotive applications.



Castrol Red Rubber Grease 500g

SKU: REDRG

For use on automotive brake assemblies, rubber components, and hydraulic components.

Oil System & Lubrication

Engine Oils, Gear Oils, Additives & Coolant



Choosing the right oil

Choosing the right engine oil for your veteran, vintage or classic vehicle is essential for ensuring optimum running condition and maximum wear protection for your engine. To make selection easier, Castrol now produce a range of famous, classic oil grades and greases to the correct formulations and viscosities, as originally recommended by the vehicle manufacturers—though now using the latest technology, with low detergent formulations to better protect your vehicle.



Many motor manufacturers originally specified Castrol in their handbooks and now you can follow those original recommendations. Castrol's oil recommendations for vintage, veteran and classic vehicles date back to the turn of the last century and most of these are now captured in their excellent **Castrol Classic Oil Finder** database, a link to which is in each product description. Some very early applications as well as an interesting period explanation of motor car lubrication is attached to the product description on our website.



Castrol CLASSIC XL20w/50
SKU: XL20W/50

A conventional multigrade engine oil of good all round performance, ideally suited to older technology and classic car engines.



Castrol CLASSIC XL30 Monograde
SKU: XL30

For pre-1950 veteran, vintage & classic cars, high quality SAE 30 engine oil, also used in most types of manual gearboxes fitted to vintage & classic cars.



Castrol CLASSIC XXL40 Monograde
SKU: XXL40

Summer grade for pre-1950 cars and pre-1970 motorcycles. It is ideally suited to older technology and classic car engines.



Castrol CLASSIC GP50 Engine Oil
SKU: GP50

For pre-1950 performance cars & pre-1970 motorcycles. Offers excellent high temperature performance. Very high level of engine wear protection.



Castrol CLASSIC ST90 Gear Oil
SKU: ST90

For gearboxes and differentials where a non low EP gear oil specified, ideal for straight cut gears. NOT be used for hypoid gears.



Castrol CLASSIC D140 Gear Oil
SKU: D140

A high viscosity gear oil suitable for the lubrication of most types of gears including helical, spur, bevel and worm. NOT be used for hypoid gears.



Castrol 4 Life Coolant

SKU: 4LCOOL

Forlife is now predominantly used in classic vehicles and performance cars, where an extra safety margin against overheating is required and a lower running engine temperature is beneficial. Forlife is suitable for all classic cars that require a traditional ethylene-glycol (IAT) coolant. It provides exceptionally high heat transfer from engine block to coolant.

- Exceptional heat transfer capability.
- Protects cast iron, brass and aluminium components
- PH balanced, no acidic impurities or lime scale
- Long term protection for cars in use or in storage.
- Preserves rubber cooling hoses for longer service

Forlife noticeably reduces engine running temperature in all conditions, and with a boiling point to a maximum of +180°C Forlife provides that extra safety margin that hopefully your classic car will never need.



Castrol CLASSIC EP90 API GL-4 Gear Oil
SKU: EP90

Extreme pressure multi-purpose gear oil. For hypoid and non-hypoid applications. Recommended for conventional spiral bevel final drives.



Castrol CLASSIC EP140 API GL-4 Gear Oil
SKU: EP140

Application as EP90—Its higher viscosity makes it particularly suitable for older vehicles where some wear with age may have occurred.



Castrol CLASSIC TQF (SAE20) ATF
SKU: TQF

Automatic transmission fluid for Classic Vehicles. Can be used where Castrolite is specified for primary chain case or gearbox, and for classic motorcycle front forks.



Classic Valve Master 250ML
SKU: VALVEM

Provides the best protection against valve seat recession after lead.



Classic Valve Master PLUS 250ML
SKU: VALVEM+

Provides the ultimate protection against valve seat recession, plus friction modifiers.

Oil System & Lubrication

Ethanol Stabiliser



Ethanol – what is it?

Ethanol is an alcohol produced from bio-mass sources such as sugarbeet or corn. As a renewable element rather than a fossil fuel, it is added to petrol to lower the carbon footprint. E5 fuel has up to 5% ethanol component and is branded with names such as Supreme, Super, V-Power and Excellium. The new, much more widely available E10 fuel contains 10% ethanol.

What's the problem?

For most cars and motorcycles built since 1996, other than a small loss of power and an increase in fuel consumption, ethanol fuels are not a problem. There can be serious issues for older vehicles not designed for modern fuels. As ethanol breaks down it forms acids that attack the metals used in older carburettors and fuel pumps as well as the non-compatible hose, seal and gasket materials, with the resultant risk of leaks.

Ethanol-blended fuels are a particular problem for older classic and vintage vehicles because they are often not driven on a regular basis, giving the fuel time to separate. The key term here is "phase separation". Ethanol tends to absorb the water naturally found in petrol and in the air. This results in the separation of the ethanol-water mix from the petrol, forming layers in the tank.

How does ETHANOLMATE help?

ETHANOLMATE is the leading product for classic vehicles for use with the new ethanol-containing petrol. It functions as an acid corrosion inhibitor, fuel stability improver and biocide. ETHANOLMATE helps prevent fuel degradation in storage in the fuel tank. It provides excellent protection against fuel system corrosion due to increased acidity which can occur when petrol-containing ethanol is stored for any length of time. Protects against gum and resin build-up and carbon deposits. Cleans carburettors, injectors, filters and fuel lines of existing deposits. Can improve driveability, increase fuel economy, restore power and reduce emissions. Suitable for use in 2 and 4 stroke engines.

How do I use ETHANOLMATE?

Just add to the tank when refuelling using the graduated dispenser. A bottle treats 250 litres of petrol. Most engines manufactured prior to 1996 would benefit from the use of ETHANOLMATE.

ETHANOLMATE



Worried about Ethanol damage to your classic car or motorcycle?

- Prevents acid formation due to deterioration of the ethanol component in modern fuels
- Protects against acid corrosion in metal fuel line components
- Protects against gum and resin build up and carbon deposits
- Cleans carburettors, injectors, filters and fuel lines of existing deposits
- Can improve driveability, increase fuel economy, restore power and reduce emissions
- Suitable for use in 2 and 4 stroke engines
- Can be used with modern e5, e10 fuels and with catalytic converters
- 250ml treats 250 litres

Ethanolmate
Stabilizes
Prevents and
Protects



Endorsed by the FBHVC as a protective fuel additive

FLEXOLITE

Alternators, Dynalites & Starters

Powerlite Alternators



Powerlite—Made in the UK

Powerlite make a range of alternators including compact lightweight units ideal for competition cars where weight and space are at a premium. The alternators are available in a wide range of outputs and bracket configurations enabling the selection of a suitable unit to meet your requirements. The range includes adaptable 'multi-mount' units as well as those configured to replace standard units without modification. Simple wiring affords easy fitment when replacing original equipment on a wide range of vehicles. There is a 3 Year Warranty on Powerlite Alternators.



Powerlite Universal 55amp Lightweight

SKU: RAC001

Universal "in-line" fitting with two bottom fixing lugs (1 thick, 1 thin). Compact, lightweight, high performance alternator. Suitable for race engines where space is at a premium.

Amps: 55 A
Shaft diameter: 15 mm
Voltage: 12v
Weight: 2.90 kg



Powerlite Universal 50amp Lightweight

SKU: RAC002

Universal "in-line" with three fixing lugs. Compact, lightweight, high output alternator. Suitable for race engines where space is at a premium. Built to withstand vibration and engine harmonics

Amps 50 A
Shaft diameter 15 mm
Voltage 12v
Weight 3.30 kg
Wiring config: RAC902



Powerlite Universal 40amp Lightweight

SKU: RAC003

Universal "in-line" fitting with two bottom fixing lugs (1 thick, 1 thin). Compact, lightweight, high performance alternator. Suitable for race engines where space is at a premium.

Amps: 40 A
Shaft diameter: 15 mm
Voltage: 12v
Weight: 3.30 kg
Wiring config: RAC902



Powerlite Universal 45amp Lightweight

SKU: RAC65

Compact, lightweight, high output alternator, suitable for race engines where space is at a premium. Multi positional fixing bracket for even greater fitment flexibility—this unit can be fitted anywhere!

Amps 45 A
Shaft diameter 15 mm
Voltage 12v
Weight 3.10 kg
Wiring config: RAC902



Lucas ACR Type 50amp Lightweight

SKU: RAC068

Suitable for Ford BDA, Pinto, X-Flow, A series engines, A + B series BMC and BL types, Rover V8. "Multi-mount" compact alternator designed by Powerlite to the exact pattern & size of the original Lucas unit.

Amps: 50 A
Shaft diameter: 15 mm
Voltage: 12v
Weight: 3.00 kg
Wiring config: RAC902



Classic Alternator 18ACR Type (Right)

SKU: PCA00100

Equivalent to 18 ACR Lucas type "right hand" unit. Powerlite Classic Alternator. Multiple applications. Versatile and easy to fit, one of the most popular alternators for classic & motorsport applications.

Amps 34 A
Shaft diameter 15 mm
Voltage 12v
Weight 3.10 kg



Classic Alternator 18ACR Type (Left)

SKU: PCA00101

Equivalent to 18 ACR Lucas type "left hand" unit. Powerlite Classic Alternator. Multiple applications—versatile and easy to fit, it soon became one of the most popular alternators for classic & motorsport.

Amps: 34 A
Shaft diameter: 15 mm
Voltage: 12v
Weight: 3.10 kg



Classic Alternator—A115 Type Right Hand

SKU: PCA00226

Re-manufactured A115 Lucas type "right hand" alternator. This unit is suitable for multiple British classic applications. Negative Earth only. An upgrade for PCA00100.

Amps 45 A
Voltage 12v
Weight 3.10 kg
Polarity: Negative

Alternators, Dynalites & Starters

Powerlite Dynalites



Lucas C40 Type-Neg. Earth

SKU: RAC006
 Amps: 40 A
 Bracket distance: 144 mm
 Polarity: Negative Earth
 Shaft diameter: 15 mm
 Weight: 3.50 kg



Dynalites from Powerlite

The original alternator that looks like a dynamo! Designed, tested and built by Powerlite, this unit delivers the performance of a modern alternator whilst retaining the period look of a dynamo. Built with OE rated components, every Dynalite comes with a Lifetime Warranty.

- Identical Fitting To Original
- Up to 80% More Powerful
- Up to 40% Lighter
- Positive & Negative Earth Models
- Tacho Drive models

What changes are needed to run a Dynalite?

The Dynalite unlike a dynamo is self regulating, therefore the control box is redundant. The control box can simply be bypassed or use the control box as a junction point with two small wiring changes.

The Dynalite uses the same output shaft as the original dynamo allowing the original fan and pulley to be used. Dynalites MUST run a cooling fan. Original types are acceptable. Dynalites operate best using a 2:1 pulley ratio. It is sometimes necessary to use smaller pulleys on large saloons with low revving engines.

New units with the appearance of original Lucas C40, C42 and C45 type dynamos!

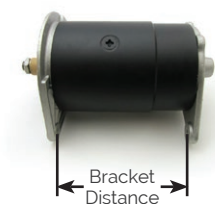

Fitment	mm
Lucas C40/C39	144
Lucas C40L	154
Lucas C42	173
Lucas C45	165



Lucas C40 Type-Neg. Earth, L/H Mount
 SKU: RAC006LH

Amps: 40 A
 Bracket distance: 144 mm
 Polarity: Negative Earth
 Shaft diameter: 15 mm
 Weight: 3.50 kg



Lucas C40 Type-Pos. Earth
 SKU: RAC024

Amps: 40 A
 Bracket distance: 144 mm
 Polarity: Positive Earth
 Shaft diameter: 15 mm
 Weight: 3.40 kg



Lucas C40L Type-Neg. Earth, Long Body
 SKU: RAC006L

Amps: 40 A
 Bracket distance: 154 mm
 Polarity: Negative Earth
 Shaft diameter: 15 mm
 Weight: 3.70 kg



Lucas C40L Type-Pos. Earth, Long Body
 SKU: RAC025

Amps: 40 A
 Bracket distance: 154 mm
 Polarity: Positive Earth
 Shaft diameter: 15 mm
 Weight: 3.60 kg



Lucas C40 Type-c/w Tacho Neg. Earth
 SKU: RAC006T

Amps: 40 A
 Bracket distance: 144 mm
 Polarity: Negative Earth
 Shaft diameter: 15 mm
 Weight: 3.40 kg
 Rear Tacho connection



Lucas C40 Type-c/w Tacho Pos. Earth
 SKU: RAC030T

Amps: 40 A
 Bracket distance: 144 mm
 Polarity: Positive Earth
 Shaft diameter: 15 mm
 Weight: 3.50 kg
 Rear Tacho connection



Lucas C42 Type-Neg. Earth
 SKU: RAC007

Amps: 40 A
 Bracket distance: 173 mm
 Polarity: Negative Earth
 Shaft diameter: 15 mm
 Weight: 3.60 kg



Lucas C42 Type-Pos. Earth
 SKU: RAC026

Amps: 40 A
 Bracket distance: 173 mm
 Polarity: Positive Earth
 Shaft diameter: 15 mm
 Weight: 3.50 kg



Lucas C45 Type-Neg. Earth
 SKU: RAC008

Amps: 60 A
 Bracket distance: 165 mm
 Polarity: Negative Earth
 Shaft diameter: 17 mm
 Weight: 4.20 kg



Lucas C45 Type-Pos. Earth
 SKU: RAC014

Amps: 60 A
 Bracket distance: 165 mm
 Polarity: Positive Earth
 Shaft diameter: 17 mm
 Weight: 4.20 kg

Alternators, Dynalites & Starters

Starter Motors



High Torque Starter Motors from Powerlite

Powerlite produce a wide range of **high-torque gear reduction** starter motors. These lightweight units offer increased cranking speeds and considerably more cranking power than original units, whilst drawing less current from the battery. They are ideal for competition applications, where engines have been tuned–and anytime when extra starter motor performance would help starting the car reliably. 2 Year warranty.



RAC500–Ford Kent X-Flow Unit



RAC101–Triumph GT6 Unit



Powerlite Starter Installation

Powerlite starters are a direct replacement for original units and require no modifications to the vehicle on which they are installed, as they work for both positive and negative polarity (except Slimline a & Microstart range). The compact lightweight units are often easier to install than the original unit and units have been modified where necessary to aid fitment.

Do I still need the bulkhead solenoid?

All Powerlite starters are designed with an in built solenoid. However, these can be bypassed by using a link wire (supplied where necessary). If your original starter was an inertia type then your vehicle would have a bulk head (remote) solenoid. You may use the link wire attached to the unit which bridges the motor to the solenoid. Connect the main battery feed to the battery stud, taking care not to over-tighten the nut. Your bulkhead solenoid is still operational – when energised, the link wire acts as a bridge between the motor and in built solenoid on the unit.

Or if you do not wish to use the bulkhead solenoid, remove the link wire on the Powerlite unit and bypass the bulkhead solenoid. Fit the ignition feed wire to the spade terminal or stud on the Powerlite starter.

SKU No. Application

RAC417	Alfa Spider 2000 S1, 2, 3, 4
RAC420	Alfa Guilietta, Guilia, Gt Junior & 1750 Sv
RAC428	Austin 7 (side mount)
RAC467	Austin 7 (engine mount)
RAC403	MG Midget, Healey Sprite, Austin A series
RAC199	Austin "Big" Healey, 100/4, 100/6, 3000
RAC519	Ford 8hp Model Y (12v)
RAC441	Ford Eg3a 10hp Side Valve engine (12v)
RAC500	Ford Kent X-flow & pre X-flow
RAC800	Ford Kent, X-flow/Pre X-flow (110 teeth ring gear)
RAC110A	For Ford Pinto OHC
RAC407	Ford Essex V4 and Ford Essex V6 engines
RAC517	Ford V4 and V6–Taurus and Cologne engines
RAC109	Ford BDA engine, LOLA T360, T450 and T460
RAC486	Ford Cosworth, Escort V, Sierra II, RS Cosworth 2.0
RAC461	Hillman Imp, Husky, Singer Chamois, Sunbeam Imp,
RAC301	Jaguar, all XK models
RAC408	Jaguar Mk II and XK150 Automatic
RAC302	Jaguar E Type, Mk II. Also MG TB & TC
RAC303	Jaguar E Type Straight 6 4.2 litre
RAC404A	Jaguar V12 5.3 litre (1971-1981)–29mm pinion
RAC404	Jaguar V12 5.3 litre (1971-1981) -25mm pinion
RAC300	Jaguar 4.2 Straight 6 (NOT E Type)
RAC472MS	Lotus Elan S1, S2, S3, S4 and Sprint
RAC418	Lotus Cortina / Morgan X flow, Pre X flow
RAC418A	Lotus Cortina with the 132 teeth ring gear.
RAC418B	Lotus Cortina with the 135 teeth ring gear
RAC401	MGA, MGB (inertia type) and MG TD, TF
RAC801	MG Midget, Morris Minor, Austin Healey Sprite etc
RAC184	MGB, MGC pre-engaged
RAC463	Classic Mini replaces Inertia type on 850cc–1275cc
RAC468	Classic Mini- verto flywheel 1000–1275 upto 1982
RAC802	Classic Mini, Lotus Elan where inertia unit was fitted
RAC416	Rover K series 1.1, 1.4 & 1.6 engines
RAC409	Rover K Series1.8, T series 2.0. Lotus Elise S1, S2
RAC318	Rover V8 engines
RAC424	Land Rover 2.25 petrol engine
RAC102	Triumph TR3A TR4 TR4A
RAC100	Triumph TR5, TR6, TR250 and 2000
RAC101	Triumph GT6 Mkl, II, III, and TR2/TR3/TR4
RAC406	Triumph Dolomite Sprint and TR7
RAC400	Triumph Stag 1970 to 1977
RAC471	Vauxhall 20XE, C20XE, C20LET (inc Westfields.)
RAC415	Vauxhall slant engine–Esprit, Excel, Elite, etc

Steering Wheels

Brooklands & Moto-Lita

All our steering wheels are designed and made in the UK. The Bluemel "Brooklands" wheels are made from the original tooling and traditional materials. Samples of range shown below.



Classic British Steering Wheels

Hand crafted for the best driving experience possible. You'll feel it every time you get behind the wheel—that pleasure is priceless.

Brooklands Pattern Bluemel Steering Wheels

Quality Brooklands pattern Bluemel steering wheel as fitted throughout the period 1930 to 1960 to numerous vehicles. Current applications also include sports and kit cars.

Moto-Lita Steering Wheels

The Classic British Steering Wheel, made by true craftsmen since 1957. When you fit a Moto-Lita steering wheel you're not just fitting a beautiful, ergonomically designed steering wheel made in the best traditions of British engineering—you're fitting a piece of living history: a steering wheel with a live connection to the heritage and heyday of British motor-sport. These steering wheels are in high demand though we endeavour to keep the range below in stock, if we are out of stock and have to order from Moto-Lita, please allow for a 10 to 12 weeks delivery.



14" Bluemel Brooklands Pattern Black
SKU: CA1339-14

Manufactured to the same pattern as the larger wheels using new tooling. Stainless steel spokes with chrome separators and black outer moulded grip.



15.5" Bluemel Black Brooklands Pattern
SKU: CA1339-15.5

Small pattern quality Brooklands pattern as fitted throughout the period 1930 to 1960 to numerous vehicles.



17" Bluemel Brooklands Pattern Black
SKU: CA1339-17

Larger wheel, as used on MG TA, TB, TC but looks good on many cars from 1930's to 1950's.



15.5" Bluemel Ivory Brooklands Pattern
SKU: CA1339-15.5-Ivory

Chrome separators with ivory outer moulded grip. Also available in 14" & 17"



Steering Wheel Repair Kit
SKU: CA1323

Repair old cracked and crazed wheels, enabling refurbishment to high standard. Kits for black, brown, cream, grey & green.



Brooklands Centre Boss MGA Pattern
SKU: CA1339D

MGA spline pattern, centre hole measures approx 18.5mm, without pinch bolt—used on MGA



Brooklands Centre Boss MG TC Pattern
SKU: CA1339B

Polished aluminium body (81mm diameter) chrome plated centre. MGTC spline pattern. Centre hole measures approx 18.5mm, with pinch bolt



Brooklands Centre Boss Morgan Pattern
SKU: CA1339C

Plain pattern spline for Morgan up to 1971. Polished aluminium body.



Brooklands Centre Boss MG Pattern
SKU: CA1339E

Polished aluminium body (81mm diameter) chrome plated centre. TD/TF twin key pattern. Centre hole tapers from 22.35mm to 20.30mm



Bluemel Enamel Steering Wheel Block
SKU: CA1339enamel

Bluemel Brooklands pattern steering wheel enamel block. Cross drilled with five 4.2mm holes.



Moto-Lita Classic Three Wood, Dished, Thin
SKU: CL3-15DPS

The Classic Three range of wheels typify wheels fitted to sports and racing cars of the 1950s and 1960s.



Moto-Lita Mark 5 Brown Wood 14"
SKU: MK5-14FP

Laminate Rim (Riveted) Supplied with a top ring and screw set. A new addition to the Moto-Lita range.



Moto-Lita Classic Four Black Leather 15"
SKU: CL4-15FBAL

The Classic Four is ideally suited for earlier classic cars dating from 1930s to the late 1950s.



Moto-Lita Mark 4 Black Leather 14"
SKU: MK4PB-14DPPLAIN

Dished Leather Rim Mark 4 Steering Wheel, Perforated Leather, polished plain stainless steel spokes.



Moto-Lita 15" Jaguar E-Type
SKU: E15FPOE-T

Original specification Jaguar E-type wheels for Series 1, 1.5 and 2. This wheel fits onto the original OEM boss.

Pedal Rubbers

Holdtite

Replacement rubbers for accelerator, clutch and brake pedals were all the rage back in the 1950s. Holdtite pedal rubbers were available for all the leading motor vehicles of the day. We have a range of over 40 fitments. Get a grip!

Holdtite PEDAL RUBBERS



**Special Pedal Rubber
Ford**
SKU: HT100L

Equivalent to original Holdtite pattern No.100. Handed. Internal recess for pedal vertical and top dimensions 2 3/8" x 2 3/8"



**Special Pedal Rubber
Ford**
SKU: HT100R

Equivalent to original Holdtite pattern No.100. Handed. Internal recess for pedal vertical and top dimensions 2 3/8" x 2 3/8"



**Round Pedal Rubber
Austin**
SKU: HT9

Internal recess for pedal size 2 5/16" diameter. Overall size 2 5/8" diameter. Aperture 1 5/8". Original applications inc - Austin



**Oblong Pedal Rubber
Land Rover, Ford**
SKU: HT14

Internal recess for pedal size 2 1/2" x 3 21/32". Overall size 2 13/16" x 4" Original applications - Land Rover, Ford Commercial



**Oval Pedal Rubber
Daimler, Singer**
SKU: HT23

Internal recess for pedal size 1 27/32" x 2 15/16". Overall size 2" x 3 1/4" Original applications - Jowett, Daimler, Singer, Wolseley



**Oblong Pedal Rubber
Jaguar**
SKU: HT108

Oblong shape. Internal recess for pedal size 1 1/4" x 5 1/8". Overall size 1 1/2" x 5 7/16". Original apps- Jaguar



**Round Pedal Rubber
Austin**
SKU: HT25A

Internal recess for pedal size 1 1/2" diameter. Overall size 1 3/4" diameter. Original apps include - Austin



**Oblong Pedal Rubber
Hillman, Morris**
SKU: HT64

Internal recess for pedal size 1 3/16" x 1 9/16". Overall size 1 13/32" x 1 3/4". Original apps include - Hillman, Morris



**Round Pedal Rubber
Austin**
SKU: HT36

Internal recess for pedal size 1 1/2" x 2 1/4". Overall size 1 5/8" by 2 3/8". Aperture 1" x 1 3/4". Original apps include - Vauxhall, Hillman, Singer



Narrow Oval Rubber
SKU: HT48

Internal recess for pedal size 1 11/16" x 3 7/16". Overall size 2" x 3 3/4". Original applications - MG, Humber, Jaguar. Very close to #44



**Square Pedal Rubber
Bedford, Ford, Morgan**
SKU: HT26

Internal recess for pedal size 2 1/2" x 2 1/2". Overall size 2 3/4" x 2 3/4". Original apps inc Bedford, Ford, Morgan.



**Domed Pedal Rubber
Humber, Sunbeam**
SKU: HT98

Internal recess for pedal size 1 7/8" x 1 3/4". Overall size 2 3/32" by 1 15/16". Apps - Hillman, Humber, Singer, Sunbeam



**Domed Pedal Rubber
Austin Healey, Bedford**
SKU: HT109

Internal recess for pedal size 1 7/8" x 2 1/2". Overall size 2 1/8" x 2 3/4". Original Apps - Austin Healey, Bedford



**Oblong Pedal Rubber
Triumph**
SKU: HT106

Internal recess for pedal size 1 1/2" x 3". Overall size 1 13/16" x 3 5/16". Original applications - Triumph



**Round Pedal Rubber
Austin, Wolseley, Allard**
SKU: HT73

Internal recess for pedal size 3" diameter. Overall size 3 5/16" diameter. Apps - Austin, Wolseley, Allard

Stoneguards & Rims

Mesh Stoneguards & Headlamp Rims

A wide range of period wire mesh stoneguards to suit our front lamps in chrome & nickel plate, as well as stainless steel. Replacement headlamp rims.



5 3/4" Stoneguard PAIR- Chrome Plated

SKU: 575STONECHR

Pair of 5-3/4" head lamp stone guards in Chrome plated steel. Includes brackets.



5 3/4" Stoneguard PAIR- Stainless Steel

SKU: 575STONESS

Pair of 5-3/4" head lamp stone guards in stainless steel. Includes brackets.



7" Convex Headlamp Stoneguard Stainless

SKU: CA1152SS

Convex stone guards for the standard 700 series classic car lamps. Held with three clips headlamp rim (no drill holes required). Pair



Base Mounted 6" Guard for 5 3/4" lamps

SKU: CA800

Authentic reproductions of an original design available in the 1950's and 1960's. Perfect for FT27 & 576 Series Lucas type lamps



Base Mounted 7 1/2" Guard for 7" lamps

SKU: CA800A

Authentic reproductions of an original design available in the 1950's and 1960's. Perfect for CLR700 Lucas type lamp.



8" Headlamp Guard- Chrome on Brass - Pair

SKU: CA808-C

Quality flat headlamp stone guards 8" diameter, which are attached by 3 knurled nuts to the headlamp rim which needs to be drilled.



9" Headlamp Guard- Nickel on Brass - Pair

SKU: CA809-N

Quality flat headlamp stone guards 9" diameter, which are attached by 3 knurled nuts to the headlamp rim which needs to be drilled.



10" Headlamp Stone Guard-Nickel on Brass

SKU: CA810-N

Quality flat headlamp stone guards 10" diameter, which are attached by 3 knurled nuts to the headlamp rim which needs to be drilled. Pair



12" Headlamp Stone Guard-Chrome - Pair

SKU: CA811-C

Quality flat headlamp stone guards 12" diameter, which are attached by 3 knurled nuts to the headlamp rim which needs to be drilled.



8" Headlamp Stone Guard-MG Type- Pair

SKU: CA808-MG

Quality flat headlamp stone guards 8", thin rims, diagonal mesh. Used on the early MG's (except late TC's) Pair.



8 1/2" Outside Push Fit Rim Triumph TR's

SKU: 54520073

Triumph TR's, Spitfires, Daimler Dart. Retained by the clip inside the rim. For use with 7 inch light units.



8" Headlamp Rim for 7" Light Units

SKU: 54520651

MG TF, MGA, MGB, Rover P4, Cobra, etc. Chrome plated. Outside screw fitting.



8" Headlamp Rim for 7" Light Units

SKU: 54520650

Mini, Morgan, Morris Minor early Land Rover. Chrome plated. Supplied with screw and rubber washer



Jaguar XK120 Headlight Rim

SKU: 553620

Chrome on spun steel. For use with Lucas PF770 lights. 8" screw fitting for standard units.



Jaguar XK140/XK150 Headlight Rim

SKU: 554903

Chrome plated on steel. Screw fitting. For fitting with 7 inch J Light or other standard units



7 1/2" PF770 type Rim for Aston Martin DB2-5

SKU: 553978

Headlamp rim, chrome on steel, to fit Aston Martin DB2-5, as fitted with original Lucas PF770 lights.



8 1/2" Headlamp RIM for Austin Healey 3000

SKU: 54522515

As fitted to Austin Healey 3000 BJ8. Chrome plated. Screw Fitting. 215 mm external diameter



5 3/4" Plastic Black Wipac Headlamp Rim

SKU: S5723

5 3/4" Textured black plastic headlamp rim

We can also supply sheets of brass double crimp wire mesh for stoneguards and radiator grills. Diagonal or square format with 11mm square aperture and 1.6mm wire diameter

Switches

Ignition, Foot Switches, Indicator Switches

SVC supply a huge range of switches of all different types. Please visit www.s-v-c.co.uk to see the entire range we hold in stock as well as the technical details of each switch.



Floor Mounted Dip Switch

SKU: CA1211

Foot operated dip switch for mounting through floor. Switch pillar is 45mm tall, fixing holes 38mm.



Dip Switch Equivalent to Lucas Part 9RW

SKU: 9RW

A very neat period switch originally used to control fog & spot lamps, dipping reflectors & reversing lamps.



Floor Mounted Dip-As Lucas 31284

SKU: 442

Floor mounted traditional dip switch for foot use, equivalent to Lucas part number 31284.



Floor Mounted Dip-As Lucas 34790

SKU: 34790

Lucas type 34790 floor mounted dip switch as fitted to Mini, MG, TR5 and early TR6. Equivalent to Lucas type 34790



Rotary Lighting Switch-Ivory

SKU: CA1446V

Useful 4 position (off, side, dip, main) switch with ivory lever to fit a metal dash. 6 screw terminals to rear.



Floor mount starter As Lucas ST18

SKU: CA22

As Lucas ST18 (076411, also SRB312) heavy pattern for connecting into starter/battery cables.



PLC5 Ignition/Light Switch, as 34057

SKU: 836A

Combined key on/off and off/side/head lamp switch, equivalent to the original Lucas PLC5 type switch.



Barrel And Key Set For Prs3 Ignition Switches

SKU: IGBAR2

Barrel and 2 keys for Lucas type 31270, PRS3 ignition switches (3H1557)



Four Position Ignition Switch as Lucas 34680

SKU: 34680

Four position ignition switch-Auxiliary (left) Off, On and Start. Spade connections. Needs 20mm hole in dash.



Two Position Ignition Switch, off/on

SKU: 443

Two keys. Requires 19mm dia. hole.-2 key position, off/on positions only.



SPB120 Type Surface Mounted Indicator Switch

SKU: SPB120-BROWN

A super reproduction with a very positive switch action with body in correct brown bakelite colour. Colour matched to original switches. Supplied with mounting kit including link bar. We also offer correctly coloured ivory and black versions of this switch. Indicator bulb under screw down crown in centre. Re-manufactured part equivalent to Lucas 31190D SPB120 panel mounted indicator switch. Domed raised switch body assembly with moulded lever in brown bakelite. Black, flat oval base mount (40mm high x 54mm wide) with mounting holes at 46mm centres to enable mounting on to any flat panel. Brass screw terminal connections to rear. Unavailable in brown and ivory for a long time.



Repair Kit For SPB120-All Except Body + Lever

SKU: SPB120-REPAIR

Bakelite switch base with brass terminal connections 3 piece brass sprung roller contact assembly, etc with red lens and spring.



TS82 Type Surface Or Stalk Mounted Indicator

SKU: TS82

Re-manufactured part equivalent to Lucas TS82 panel and column mounted rotary 3-way indicator/Traficator switch.



TS82 Base Plate-Column Mounted Stalk

SKU: TS82-S58

For mounting TS82 switch to the ST58 column mounted stalk controls.



Indicator Switch Panel Mounted-Black/Ivory

SKU: 928

Panel mount indicator switch. Requires 25mm hole through metal panel. Overall diameter 37.5mm at rear.

Switches

Indicator Switches & Replacement Knobs



Surface Mount Switch Trafficator-'Starlight'
SKU: CA986

White surface mounting trafficator indicator switch with integral flasher unit. New old stock by Starlite.



3 Position 'Rocker' Switch-On/Off/On
SKU: DUSW14

Three position Durite indicator rocker switch. Illuminated & IVA approved. Size 55mm x 26mm approx.



Indicator Switch Panel Mounted-Illuminated
SKU: 929

Illuminates in use, 12 volt application only. Requires 25mm hole through metal panel for mounting.



Toggle Type Illuminated Switch
SKU: 325302

Small illuminated indicator switch-ON/OFF/ON. 16.5mm mounting hole required.



Toggle Switch As Lucas 31743
SKU: 325302

Toggle Switch On/Off/On (Indicator function). 14.5mm panel hole required.



Column Mounted Indicator Switch
SKU: CA930

Secured with a band clip so can be removed without leaving any extra holes etc. NOT self cancelling.



Column Mounted, Self Cancelling Switch
SKU: 39974

With horn and light flash functions. Equivalent to Lucas 39974. Triumph Stag MkII



Indicator/Flash Stalk Column Switch
SKU: 35725

As Lucas 35725, Self cancelling indicator Applications include MGB, GT, MGC, Midget, Sprite.



Column mounted Indicator Switch
SKU: SQB119

Equivalent to Lucas SQB119 for AC, Triumph and Morgan. Controls indicators, lights and horn.



Self Cancelling Indicator Switch
SKU: SQB126

Equivalent to Lucas SQB126 Triumph Herald, Vitesse, Spitfire, GT, TR4, TR5, TR6, Lotus Elan S1. RHD & LHD.



Black Head/Side/Off Knob For PRS3 Switch
SKU: 316285

Headlight/Side/Off knob for the Lucas type PRS3 (31270) switch, as used on Mk1 Sprites and others.



Cream Head/Side/Off Knob For PRS3 Switch
SKU: 316286

Headlight/Side/Off knob for the Lucas type PRS3 (31270) switch, as used on Mk1 Sprites and others.



PRS3/PRS7 Knob As Lucas 316287 (H S OFF)
SKU: 316287

Brown Bakelite light switch knob with lever for PRS3/PRS7 engraved with 'H S OFF' and cream filled.



PRS3/PRS7 Knob As Lucas 316435 (H S OFF)
SKU: 316435

Black Bakelite light switch knob with lever for PRS3/PRS7 engraved with 'H S OFF' and white filled.



Replacement Knob for Lucas Horn Push
SKU: 76206/76208

Black/Cream Bakelite knob for Lucas SPB160 horn push switches.



Knob as Lucas part - 318169 (HNP Wiper)
SKU: 318169

Bakelite knob with scallop edge engraved with 'HNP WIPER'. Made from original Lucas tooling.



Knob as Lucas part - 316133 - Lights
SKU: 316133

Bakelite knob with scallop edge engraved with 'L'. Made from original Lucas tooling.



Replacement Lucas Pull Knobs (F P W L C)
SKU: Various

Black or Cream Bakelite knob engraved FPWLC Made from original Lucas tooling. 17mm across.



Replacement Lucas Pull Knobs (W L P S)
SKU: Various

Black or Cream Bakelite knob engraved W, L, P or S Made from original Lucas tooling. 19mm across.



Replacement Lucas Pull Knobs (F P W)
SKU: Various

Black Bakelite knob engraved with F, P or W Made from original Lucas tooling. 19mm across.

Switches

Pull, Push & Rocker Switches



Pull Switch Equivalent to Lucas PS7

SKU: 410

Suitable for mounting through wooden dash. Equivalent to Lucas 031218 (with screw-on knob)



Pull Type Starter Solenoid Switch

SKU: 945

Bulkhead fitting pull type starter switch (945). As type ST19/2, 76423 Ford part ET6-11450-B



Illuminated Pull Switch With Coloured Lens

SKU: SVC597

Illuminated pull switch with yellow, red, or green lens. traditional 50's/60's design.



Push/Pull Switch-Long Shank

SKU: CA981C

Suitable for wooden dash, max thickness 10mm. Fits 8mm hole. Brass terminals with screws. Black knob.



Illuminated Pull Switch Red Lens as Lucas 56SA

SKU: 56SA

Remade Lucas 56SA type pull switch with red illuminated knob. Fits 3/8" dash panel hole.



Bosch Type Aluminium Body Horn Button

SKU: CA323

Aluminium body with black push button, two terminals for wood dash. Very similar to the vintage Bosch model.



Chrome Push Starter Button

SKU: S1203

Starter Push Button Switch (Ford 1937-48 style) 15A at 6V, 20A at 12V. Hole size needed approx. 22mm



Push switch as Lucas HP19, SPB160

SKU: 434

Push button with flange for mounting on to dash, button head approximately 38mm diameter.



Stainless Push Button Dash Switch

SKU: EX588

Plated brass momentary push switch with stainless push Approx 19mm hole, long thread (15mm)



Push Button Dash Switch As Lucas SPB106

SKU: SPB106

Suitable for a starter solenoid. Used on many classics including on some AC cars as a horn push.



Durite Illuminated Rocker Switches

SKU: Various
Illuminated & IVA approved. Ideal for kit cars. Large range of symbols & functions available.



SKU No.	Application
DUSW1	Screen wash Off/On
DUSW13	Wipers-2 Speed-Off/On/On
DUSW10	Main & Dip Lights-2 position
DUSW11	Heater or Fan-3 position
DUSW12	Lights 3 Position
DUSW14	Indicator switch-On/Off/On
DUSW2	Front Spot/Fog light-Off/On
DUSW3	Rear Fog light-Off/On
DUSW4	Heated Screen-Off/On
DUSW5	Hazard-Off/On
DUSW6	Spot Light-Off/On
DUSW7	Electric Radiator Fan Off/On
DUSW8	Horn-Off/Momentary On
DUSW9	Brakes ABS Test-Off/On
DUSW15	Red Switch-Off/On
DUSW16	Green Switch-Off/On
DUSW17	Blue Switch-Off/On
DUSW18	Yellow Switch-Off/On



Durite Rocker Connect Socket

SKU: DUCON

Connector Socket and Spade Terminal kit. Connect as a block, rather than individual cables.



Durite Rocker Gang Mount Frames

SKU: DUMOU

The frames clip together to make a bank-outer ones have round corners, inners have square corners



Durite Rocker Blanking Socket

SKU: DUPLA

Connector Socket and Spade Terminal kit. Connect as a block, rather than individual cables.



Dashboard Rear Fog Light Switch With LED

SKU: FRFOGSW

Black round front fog light switch On/Off

Switches

Toggle Switches & Other Switches



**Toggle Switch
As Lucas 31780**
SKU: 31780

Austin, Bedford, Morris and Wolseley. Equivalent to Lucas part number 31780. Two way On/Off switch



**Toggle Headlight
Switch As Lucas 31788**
SKU: 31788

Toggle headlight switch Off/On/On. Ideal for Off/Sidelight/Headlight, 2 speed heater switch, etc.



**Interior Light Toggle
Switch With Cover Plate**
SKU: 606

Polished stainless steel or brass cover plate 43mm x 30mm with bevel edges. On/off. Solder Terminals.



**HD Metal Toggle
Change-Over On/On**
SKU: 0-658-02

Dolly double pole change over On/On heavy duty; two position double pole switch, nickel plated brass lever.



**LED Illuminated Toggle
Switch-Off/On**
SKU: EX894

Red, Amber, Blue, Green illuminated chrome toggle switch Off/On. 12v 25 amps.



**Green LED Toggle
Switch-On/Off**
SKU: EX895PL

High quality switch with positive action. 13mm long thread. Illuminated green lever tip.



**Vintage Clamp-On Dash
Switch-On/Off**
SKU: VINTOG1

Quickly mounts to under dash flange on most cars. Use for fog lights, wiper motors or any universal use.



**Toggle Switch On/Off
Fascia Plate**
SKU: TOGPLATE

Fascia plate for metal toggle switches with 13mm bodies



**12v Illuminated Toggle
Switch-On/Off**
SKU: BULBTOG

Amber, Blue, Green, Red. 12W BA7S bulb. 12.5mm panel hole fixing. Max panel thickness 7mm



**Off/On- Momentary
As Lucas SPB204**
SKU: SPB204

Applications include headlamp flash, screen washer etc. Equivalent to Lucas part number SPB204



**Brake Light Switch
(Pull Off)**
SKU: 415A

Connects to linkage with a spring. Contacts 'break' on pull, in relaxed position the switch is on. No cover.



**Brake Light Switch
(Pull On)**
SKU: 415

Rubber cover, connects to linkage with a spring, switch Fixing hole centres 24mm, spring ink hook 95mm relaxed.



**Brake Light Switch
(Pull On)**
SKU: BLS

FAE 24040 12V Brake light switch fitted with twin spade/Lucar connections.



**Brake Light Switch,
Bakelite Lever Type**
SKU: 7W-13480

Period brake switch. Bakelite body. Lever arm which makes contact when pulled. Originally Ford cars. RHD & LHD versions available.



**Rotary On/Off Turn
Switch - Chrome Bezel**
SKU: 768C

Rotary on-off turn switch with black knob with two flattened grips. Short shank for metal dash. Equivalent to Lucas 31276, S50, PS6 type.



**Universal Door Light
Push/Plunger Switch**
SKU: UDLS

Twin terminal push switch with self-adjusting plunger. Universal application. Use on door pillars etc.



**PPG1 Type Two Position
Switch, Pull/Twist/Pull**
SKU: 101

Switch as Lucas PPG1 style light switch with pull/twist/pull action. Fits through 10mm hole max panel



**Dash Rotary Rheostat
Dimmer Switch 78405**
SKU: 78405

Early Land Rover as well as MGA, MGB Triumph TR4 TR5 TR6 & TR7 and Aston Martin.



**Rotary Washer/Wiper
Switch**
SKU: 155496

2 speed rotary wiper switch with push to wash.





**Floor Mounted Starter
Switch As Lucas ST18**
SKU: 300

For connecting directly into starter/battery cables, as Lucas type ST18, 76427.

Tools, Consumables, Accessories

Rubber Extrusions

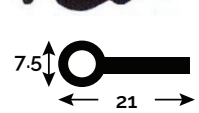
A extensive range of rubber profiles, many exclusively remade to original dimensions. Glazing strips, window seals, door frame seals, edging, wing beading and tools. Everything to replace perished or leaking seals.

	<p>Window Frame SKU: RM1 6mm base x 21mm overall, 2mm neck.</p>		<p>Hollow Bead SKU: RM20 12mm x 24mm overall, slot 2mm.</p>		<p>Hollow Bead & Tail SKU: RM40 5.5mm bead x 15mm overall, 2mm flange</p>
	<p>Rubber Extrusion SKU: RM2 10mm base x 19mm overall, 6mm neck.</p>		<p>Hollow Bead & Flap SKU: RM21 11mm bead x 38mm overall</p>		<p>Hollow Bead & Tail SKU: RM41 11mm bead x 26mm overall, 2mm flange</p>
	<p>Rubber Extrusion SKU: RM3 5.5mm base, 22mm overall, 2mm neck.</p>		<p>Edge Trim SKU: RM22 10.2mm x 4.5mm with 2mm slot</p>		<p>Rubber Extrusion SKU: RM43 Base 8mm, overall 24mm, neck 4mm.</p>
	<p>Rubber Extrusion SKU: RM4 7.3mm base, 25mm overall, 3.5mm neck.</p>		<p>Edge Trim SKU: RM23 11.5mm x 6.7mm with 3mm slot</p>		<p>Hollow Bead & Tail SKU: RM46 7.5 bead x 21mm overall, 2.3mm flange.</p>
	<p>Rubber Extrusion SKU: RM6 7.6mm base x 20mm long approx.</p>		<p>Edge Trim SKU: RM24 16mm x 4.5mm with 2mm slot</p>		<p>Extrusion & Trim SKU: RM47 Supplied with of 'chrome' filler strip</p>
	<p>Rubber Extrusion SKU: RM7 11mm across top x 20mm high</p>		<p>Square Edge Trim SKU: RM25 Three sizes, for 3mm, 4.5mm or 6mm glass</p>		<p>Long Angle SKU: RM48 15mm x 9mm x 1.8mm thickness approx</p>
	<p>Rubber Extrusion SKU: RM8 7.5mm base x 36mm long</p>		<p>U Channel + Tails SKU: RM26 For 6mm glass, 11mm tall, 10mm base</p>		<p>Rubber Extrusion SKU: RM49 Approx 12mm across base x 6mm body depth.</p>
	<p>Rubber Extrusion SKU: RM9 18mm overall, slot 10mm x 1.5mm wide.</p>		<p>U Channel & Tail SKU: RM28 For 6mm glass, 12mm deep, 11mm wide.</p>		<p>Quarterlight Seal SKU: RM51 Base 6mm, 11mm high. Overall width 23mm</p>
	<p>Rubber Extrusion SKU: RM10 6.5mm diameter with 1.5mm slot.</p>		<p>Rubber Extrusion SKU: RM29 10.5mm x 19mm overall.</p>		<p>Solid wedge SKU: RM58 Used as Sheerline quarterlight seal</p>
	<p>Rubber Extrusion SKU: RM12 flat base 20mm, height 10mm, 30mm overall</p>		<p>Roof Seal SKU: RM31 Base 12mm, top width 20mm, height 10mm.</p>		<p>Hollow T Section SKU: RM62 19mm x 6.8mm thick, reducing to 3.5</p>
	<p>Rubber Extrusion SKU: RM13 Flat base 19mm, height 9mm, 26mm overall</p>		<p>Split Tube & Tail SKU: RM33 32mm x 11mm overall, 2mm thick.</p>		<p>Rubber Extrusion SKU: RM64 38mm overall width, 2mm thickness.</p>
	<p>Hollow Bead SKU: RM15 9mm bead, 14mm overall, 7.5mm base.</p>		<p>Tank Strap Protect SKU: RM34 41mm x 5mm, 34.5mm between inside faces.</p>		<p>Glazing Strip SKU: RM634 Black or Chrome filler strip</p>
	<p>Rubber Extrusion SKU: RM17 21mm x 7mm</p>		<p>Glazing 4.5 Glass SKU: RM37A 15mm x 15mm body, flange tail 21mm long.</p>		<p>Glazing Strip SKU: RM769 Black or Chrome filler strip</p>
	<p>Rubber Extrusion SKU: RM18 3.5mm bead x 28mm wide, 1.6mm thick tail.</p>		<p>Glazing 6mm Glass SKU: RM37B 15mm x 15mm body, flange tail 21mm long.</p>		<p>Glazing Strip SKU: RM1295 Black or Chrome filler strip</p>
	<p>Rubber Extrusion SKU: RM19 base 20mm, flange 26mm extended, approx 21mm at rest.</p>		<p>Beaded Flap SKU: RM39 3.75mm bead x 20mm overall, 1.75mm thick tail.</p>		<p>Glazing Strip SKU: RM1295 Black or Chrome filler strip</p>

Tools, Consumables, Accessories

Sponge Extrusions

Sponge profiles remade to original dimensions. Soft black skinned. Profiles with "SA" in the product code have self adhesive tape ready applied, Stop the draughts and rattles with new foam rubber seals.

SPONGE PROFILES

A wide selection of of special shaped sponge profiles for sealing.

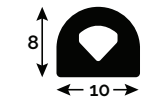

Small Hollow 'D'
SKU: SR2
10mm base x 8.5mm tall. Soft skinned black.

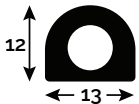

Large Hollow 'D'
SKU: SR4
13mm base x 12mm tall. Soft skinned black.

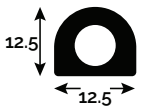

Self Adhesive 'D'
SKU: SR4SAB
MG and Jaguar Seal (O.E. part BD 2159)



Arrow Head
SKU: SR10
Black 15 x 15mm
Grey 13 x 13mm



Hollow Quadrant
SKU: SR14
Black skinned hollow section.



Hollow Gutter
SKU: SR15
Black skinned section. 16 x 14mm



Square with Lip
SKU: SR20
Firmer skinned section 12.5 x 12.5mm



Grey Domed Oblong
SKU: SR21
GREY ONLY 17mm x 12mm



Door Seal
SKU: SR24
Softer black skinned section



Flanged Seal
SKU: SR25
Base 16mm wide, overall 20mm x 19mm



Curved Lip Seal
SKU: SR27
Flat base approx 13mm wide, 15mm high



Hollow 'D'
SKU: SR31
14mm base x 12mm tall, wall 1.5mm



Solid Arrow Head
SKU: SR36
12mm tall x 10mm wide approx. Soft skin



Land Rover Door
SKU: SR97
20mm base, 24mm tall flange section

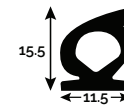

Sponge Extrusion
SKU: SR117
Base 8.3mm, overall 15mm x 16mm

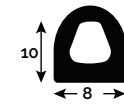

Dual Hardness Seal
SKU: SR126SAB
Used in many classic car doors & windows

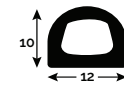

Sponge 'D' Section
SKU: SR131SAB
Used for many classic sealing applications

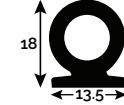

Sponge 'D' Section
SKU: SR132SAB
Self adhesive backed expanded EPDM

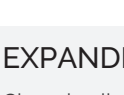

Door Seal
SKU: SR147SAB
Self adhesive, dual hardness door seal

SPONGE SECTIONS

Skinned round expanded sponge cord, good for general sealing applications.
SKU: SRC & SHR



● Full-size sections.
Round 4mm to 12mm
Half-round 12.5mm to 25mm

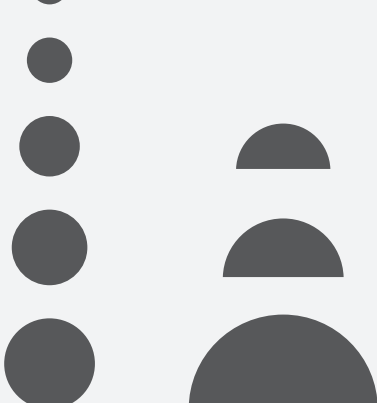

EXPANDED SPONGE STRIP

Extruded sponge rectangular section, skinned on all four sides.
SKU: SSS



Rectangular sections from 3mm to 13mm thick, and upto 25mm long



EXPANDED NEOPRENE

Closed cell sponge with self adhesive backing strip. Will only absorb moisture into the cut hollow cell.
SKU: ANS



- 3mm x 8mm
- 3mm x 13mm
- 3mm x 25mm
- 6mm x 25mm
- 6mm x 38mm
- 10mm x 25mm
- 10mm x 38mm
- 12mm x 25mm
- 12mm x 38mm
- 20mm x 25mm
- 25mm x 25mm
- 25mm x 38mm

Tools, Consumables, Accessories

Bonnet Catches, Corners, Tape & Releases

A huge range of vintage & classic type bonnet catches as well as rubber rally types. Bonnet tape to stop the rattles and rubber corners to protect the paintwork. Remote cable releases for bonnet locks.



Bonnet Catch With Bonnet Plate & Stud
SKU: 116

Chrome plated bonnet catch as fitted to Morris Minor, MG J2, Wolseley Hornet etc. Catch size 133mm overall.



Spring Bonnet Catch with Top Catch
SKU: 468

Nickel plated finish, 125mm long, a good value spring catch to hold a bonnet down, with top catch.



Bonnet Fastener, Twist To Release
SKU: 407

Chrome on brass, height fitted 95mm. Mounting hole centres approx 28mm horizontal, 22mm vertical.



Bonnet Catch with Chrome Finger Loop
SKU: 426

Approx 118mm long. High quality spring loaded pull catch with finger loop pull ring, powder coated finish.



Bonnet Catch Large Chrome or Nickel
SKU: 149

Top quality catch. Chromium or nickel plated on brass. Mountings approx 90mm apart, 135mm overall.



Bonnet Catch Small Chrome on Brass
SKU: 148

Small rubber buffer on back. Base plate to top of hook eye approx 92mm (will extend to max of 108mm). Our most popular catch.



Screw Down Bonnet Catch
SKU: 403

4 or 5 Lobe design. Ripaults, Tenax or plain top. Approx 85mm tall, 48mm round base.



Bonnet Catch Polished Stainless Steel
SKU: A-16750

91mm tall overall, base 55mm wide. Choice of 2 hole mount or 3 hole mount (shown)



Pull Bonnet Catch Wilmot Breeden Type
SKU: 138

Original equipment for Morris 8, Morgan etc. chrome on brass, approx 4.75" / 120mm long



Rubber Bonnet Fastener Large
SKU: 893

Zinc plated bracket & clip, overall length approx 122mm. Maximum extension from relaxed to tension not to exceed 10%.



Rubber Bonnet Fastener Small
SKU: 893A

Zinc plated bracket & clip. Overall length approx 54mm. Maximum extension from relaxed to tension not to exceed 10%



Bonnet release cable - Black
SKU: BONREL1

'Raised bonnet' symbol on handle. 75mm straight shaft, 1.5m flexible outer (5mm diameter), 1.5mm braided inner wire diameter.



Bonnet release cable - Red
SKU: BONREL2

Flanged (20mm diameter) 75mm straight shaft, 1.5m flexible outer (5mm diameter), 1.5mm braided inner wire diameter.



Holdtite Rubber Bonnet Corner
SKU: 260H

Right angle, original Holdtite pattern with logo and text. Side approx 45mm



Rubber Bonnet Corner Protectors
SKU: VARIOUS

Various rubber moulded corner protectors for bonnets. Protect paintwork when opening/folding.



Bonnet tape beaded type 1"
SKU: 247

Approx 4.5mm thick, this product is impregnated to produce a dark brown stiff beading - rubbing tape



Bonnet tape flat type 5/8"
SKU: 271

Approx 3mm thick. Acts as the rubbing tape between bonnet (hood) and radiator cowl and body scuttle.



Bonnet tape beaded type 5/8"
SKU: 246

Approx 4.5mm thick. Acts as the rubbing tape between bonnet (hood) and radiator cowl and body scuttle.



Bonnet tape beaded type 1/2"
SKU: 880

Approx 4.5mm thick. Acts as the rubbing tape between bonnet (hood) and radiator cowl and body scuttle.



Bonnet Rubbing Tape (Off the roll)
SKU: VARIOUS

Many different sizes and profiles of bonnet rubbing tape

Tools, Consumables, Accessories

Consumables & Materials

A selection of our range of workshop/garage consumables and materials. Everything you need to assemble, repair and replace parts on your vehicle.



VELCRO® Brand PS14 Adhesive, 20 or 30mm
SKU: VEL

Adhesive backed Velcro HOOK & LOOP strip. Sold by metre. 20mm or 30mm.



Steel Wire Wool Course, Medium, Fine
SKU: WOOL

Big 450g bundle of wire wool. Available in 3 grades. Fine, medium & course.



Oil Seal Felt Sheet 4, 6, 8, 10, 12mm
SKU: OILFELT

Hard white coloured compressed felt for cutting oil seal from. 150mm squares, larger by request.



Hard Red Fibre Sheet - 0.8mm, 1.2mm, 1.6mm
SKU: CA584 - CA586

Hard red vegetable fibre sheet for cutting washers etc. from. Supplied as a 300mm square.



Gasket Paper Jointing Material
SKU: GASK-PAPER

Gasket paper jointing - 0.25mm, 0.4mm, 0.8mm & 1.5mm thicknesses. Sheet size 1000mm x 500mm



Cork Jointing Material 1.2mm & 3.2mm
SKU: GASK-CORK

Neoprene bonded cork gasket material. Supplied in sheet size 1000mm x 500mm.

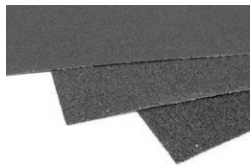

Emery Cloth Sheet 40, 80, 120 grit
SKU: EMERY

Blue cloth back 280mm x 230mm. Aluminium Oxide Course, medium or fine grade grit.



PTFE Tape Joint Installation Tape
SKU: PTFE

12mm x 12m long. Provides watertight seal for pipe fitting and installation work. Helps prevent bi-metal corrosion in threaded joints.



Denso Petro Grease Anti Corrosion Tape
SKU: CA970

For 'wrap-round' permanent spring protection, does not trap rust-forming moisture; it is a grease retaining watertight cover.



Grinding Paste - Rough & Smooth
SKU: GRPASTE

Grinding Paste Rough and Smooth (110g). Specially formulated for grinding automotive valves. Coarse and fine at either end.



Blue Hylomar Gasket Compound Non-setting
SKU: HYBLUE

Leading non-hardening and non-setting compound allows for unlimited assembly time. 100g



Exhaust Assembly Paste 140g
SKU: EXPASTE

Eases assembly of joints. Ensures gas tight seal to avoid carbon monoxide leaks. Vibration resistant.



Hylolite 'Squeeze A Gasket' Clear 85g
SKU: HYL CLEAR

Silicone based engineering grade gasket sealer forms any size or shape instantly. Remains flexible, will not shrink.



Red Hylotyte Gasket Compound 40ml
SKU: HYRED

Semi Hardening gasket and jointing compound. Improved gap filling on rough machined surfaces.



Loctite 243 Thread Locking
SKU: LOC243

Prevents loosening on vibrating parts such as pumps, motor mounting bolts, gear boxes or presses.



Heat Resistant Black & Silver Paint
SKU: HRP

For use on engines, exhausts, pipes, radiators etc 750°C max. 500ml Black or silver colour.



Self Amalgamating Rubber Tape
SKU: CA1290

Very versatile tape - moisture proof cable repairs, repair of split or leaking radiator hoses etc.



Steel Epoxy Putty Repair Stick 50g
SKU: EPOXY2

Non-rusting, steel-reinforced epoxy putty that quickly repairs or rebuilds anything made of metal.



Epoxy Resin Double Syringe 25ml
SKU: EPOXY1

General purpose epoxy resin adhesive. Twin mix syringe. Cures in about 5 minutes.



UV Light Leak Detection Fluids 25ml
SKU: RLD

Coolant. Engine Oil, Hydraulic Fluid & Water - find leaks you would otherwise miss!

Tools, Consumables, Accessories

Door Handles, Locks, Catches

Some of our most popular door handles, boot handles, locks and replacement parts.



Exterior Door Handle Locking

SKU: 805L

Small handle, as used on cobra etc. 74mm long escutcheon hole centres 35mm chrome finish.



Exterior Door Handle Locking

SKU: 532L

Chromium plated plain shaped door handle 105mm long. Large or small mounting escutcheons.



Exterior Door Handle Traditional Pattern

SKU: 700

Concave groove. 95mm long. Escutcheon hole centres approx 38mm. Commonly used on Austin 7 and Morgan.



Chromium Plated Window Winder

SKU: 539

Spring loaded escutcheon. overall length approx. 110mm. 3/8"/10mm square shaft size which fixes with cross pin.



Chromium Interior Door Handle

SKU: 578

To match our window winder handle 539. 109mm long. cross pin fixing for 3/8"/10mm square shaft.



Exterior Door Handle Locking, Chrome

SKU: 704

Slight raised rib on face 110mm long. Large or small mounting escutcheons. Shaft is an 8mm square and 110mm long.



T Boot Handle Locking, Chrome

SKU: 597

T boot handle approx 95mm long, escutcheon hole centres 44mm, chrome plated.



T Boot Handle Locking, Chrome

SKU: 220

T boot handle approx 95mm long, escutcheon hole centres 44mm, chrome plated.



Chromium Interior Door Handle

SKU: 217

114mm long, 3/8"/10mm square shaft size, cross pin fixing. Complete with spring loaded escutcheon.



Chromium Window Winder

SKU: 218

To match our 217 handle. 4.75"/120mm long. 3/8"/10mm square shaft size.



Surface Fitting Door Lock Lever Handle

SKU: 471

Base size approx 87mm x 51mm with a long tongue, particularly suitable for open bodywork, plated finish.



Door Lock Chrome Silent-Travel

SKU: 601

'Silent-travel' lock, as used on MG and other pre-war cars, chrome finish 63mm wide 75mm tall



Chrome Silent-Travel Replacement Cover

SKU: 601C

Replacement cover only, for our 601 door locks, measures approx 63mm x 75mm.



Striker Plate For Silent-Travel Lock

SKU: 602F

Face mounting plate (suit Cobra, Healey) and wedge complete. Mounting plate 95mm x 33mm.



Striker Wedge Only For Silent-Travel Lock

SKU: 602D

Replacement dovetail wedge and nut only (no mount plate). dimensions, wedge 20mm across .



Chrome Boot & Bonnet Hinge - Single

SKU: 808

Used on Lotus Elan, TVR, Hillman Imp, Reliant and kit cars. Base 135mm x 22mm. Three securing studs.



Chrome Boot & Bonnet Hinge - Pair

SKU: 209

Used on Triumph TR4, Spitfire, Herald, Nash Metropolitan, Standard 8 & 10. Base 123mm x 22mm.



Chrome Boot & Bonnet Hinge - Pair

SKU: ADA897/8

Used on Morris Minor 1951+ as bonnet hinge. Base 191mm x 26mm overall. Four securing studs.



Over Centre Catch (Lockable)

SKU: 965

Chrome on brass. Can be locked with small padlock (not supplied). base 75mm x 30mm, overall 93mm



Over Centre Catch Medium

SKU: 303

Base 77mm x 26mm, 105mm overall, chrome on brass. Six mount holes on base.

Tools, Consumables, Accessories

Catches, Accessories, Exhaust Parts



Over Centre Catch Small

SKU: 301

Base 65mm x 32mm, overall 80mm, chrome on brass. six mount holes, the single furthest holes measure 50mm apart.



Throw Over Catch Large

SKU: 304

Large throw over type safety catch, base size approx 65mm x 52mm (supplied handed), chrome on brass.



Throw Over Catch Small

SKU: 870

Small safety throw over type catch, base size approx 67mm x 22mm (supplied handed) chrome on brass.



Wire Wheel Balancing Cone 42 & 52mm Sizes

SKU: SBC

Designed to fit conventional wheel balancing machines so your local tyre fitter can balance your wheels.



Leather Bonnet or Boot Straps (pair)

SKU: STRAP

Black, Brown or Tan leather straps, used for bonnet or boot on classic race and rally cars.



Rear Lap Belt Pair (Static)

SKU: SEC210

Static Lap rear seat belts. Total length excluding buckle 165cm. Manually adjusted. E-marked.



Rear Lap & Diagonal Seat Belts -Inertia (Pair)

SKU: SEC264

Automatic lap and diagonal rear seat belts. With multi-sensitive emergency locking retractor. Total length excluding buckle 270cm.



First Aid Kit - Small 1-3 Person

SKU: FIRSAID

Small first aid kit for 1 to 3 passengers. BS8599-2 Compliant motor vehicle Kit. Supplied in a durable zip case. Guidance Leaflet



Fire Extinguisher Dry Powder

SKU: EXTINGUISH

600g Dry powder fire extinguisher ideal for car or caravan. 265mm high supplied complete with mounting bracket.



Ball Joint Covers/Gaiters

SKU: BALLCOV

6 sizes, listed by sizes/ dimensions



Exhaust wrap 50mm (2") x 15mts

SKU: EXSTWRA

Genuine vermiculite based wrap. good up to 1260°C. Reduces under bonnet temperatures



Exhaust Repair Putty 250g Tub

SKU: EXPUTTY

Exhaust Repair Putty 250g. Withstands 1000 degrees celsius. Smooth texture for easy working. .



Manifold Studs - Various sizes

SKU: EXMANST

Range to suit Vauxhall, Jaguar, MG, Rover, Austin, Ford, Triumph, Chrysler, etc.



Brass Manifold Nuts - Various sizes

SKU: EXMANST

Brass exhaust manifold nuts. 5/16" UNC, 5/16" UNF, 3/8" UNF



Perforated Strip - 12" & 24"

SKU: EXSTRIP

Perforated Strip - 12" and 24" - Ideal for exhaust fitting/ hanging, mounting horns, etc.



Tool Roll - Green Canvas

SKU: TOOLROLL-1

Superb, locally made by a Master Saddler from Malvern. Green canvas, leather tool strap. Size open 72cm x 29cm



Tool Roll - Beige Canvas

SKU: TOOLROLL-2

Very nice period style well-made, heavy-duty yellowy/beige canvas tool roll. 9 adjustable tool holder leather loops



Tool Roll - Brown Leather

SKU: TOOLROLL-3

Superb, locally made by a Master Saddler from Malvern. Waxed leather. LSize open 41cm x 31cm Eight stitched canvas pockets



Tool Roll - Castrol

SKU: TOOLROLL-4

A traditional 100% canvas tool roll, in Castrol green with an embroidered logo. With 15 pockets,



Leather Tool Bag

SKU: TOOLBAG

Superb, locally made by a Master Saddler from Malvern. 3mm waxed leather, reinforced lid and base. 37cm x 17cm x 17cm

Tools, Consumables, Accessories

Tools

A wide range of good value handtools for the home vehicle mechanic.



Spanner Set - AF Size 14 Piece, Satin Chrome
SKU: TOOL1

Open end at one end, ring spanner at other. Chrome vanadium steel. A good value workshop set.



Spanner Set - BSW Whitworth 8 Piece
SKU: TOOL2

Combination Spanners. Chrome vanadium steel. A good value workshop set. Also for use on BSF sizes.



AF Socket Set 9 Piece
SKU: TOOL3

AF hexagonal. A good value 3/8" drive workshop set. Sizes 1/4" to 3/4" across flats.



Combination Metric Spanner Set - 14 Piece
SKU: SPANMETRIC

15° offset for greater access. Hardened and tempered, drop-forged chrome vanadium. Ultra-strong ballistic nylon storage roll.



Combination Imperial Spanner Set - 14 Piece
SKU: SPANIMP

15° offset for greater access. Hardened and tempered, drop-forged chrome vanadium. Ultra-strong ballistic nylon storage roll.



Spanner Set - AF Size 14 Piece, Satin Chrome
SKU: SPANMETIMP

15° offset for greater access. Hardened and tempered, drop-forged chrome vanadium. Ultra-strong ballistic nylon storage roll.



Glow Plug and Spark Plug Socket Set
SKU: PLUGSPAN

Double-pin type universal joints. For diesel glow plugs and petrol spark plugs. Socket sizes: 8, 9, 10, 12, 14 and 16mm.



Extra-Long Screwdriver Set - 6 piece
SKU: SCREWDRIVER1

325mm shafts. Blackened magnetic tips. Comfortable soft-grip handles. Ideal for accessing recessed screws. Slotted & Phillips.



Engineers Screwdriver Set - 12 Piece
SKU: SCREWDRIVER2

Fully hardened chrome vanadium steel blades with hardened, satin finish and magnetic tips. High-impact plastic handles.



File and Rasp Set 9 Piece
SKU: FILESET

8" rasps (flat, half-round and round) and 8" files (flat, half-round, round, triangle and square) with file cleaning brush. Includes nylon wallet.



Expert Combination Pliers
SKU: COMBIPLIERS

Heavy duty chrome vanadium steel. Hardened and tempered. 2-tone soft-grip handles with slip guards.



Expert Long Nose Pliers
SKU: LONGPLIERS

Heavy duty chrome vanadium steel. Hardened and tempered jaws. 2-tone soft-grip handles with slip guards. 200mm



Circlip Pliers

SKU: CIRCLIPLIERS

For insertion and removal of both internal and external circlips. Ergonomic polypropylene handle with slip guards.



Aviation Tin Snips Set - 3 Piece
SKU: TINSNIPS

Suitable for cutting aluminium, mild steel and stainless steel sheet, uPVC sheet, wire mesh, leather, copper and plastic.



Mini Pipe Bender - 6 to 10mm
SKU: BEND1

Bends 6, 8 and 10mm copper and aluminium tubing, up to 180° Suitable for heating and hydraulic pipes. Compact size.



Ball Pein Hammers 32oz, 16oz or 8oz
SKU: BPH32/16/8

Forged steel head and shock-absorbing, high-strength fibreglass shaft with nylon surround.



16 oz Black Rubber Mallet
SKU: BRM16

Solid rubber head and hardwood shaft. Forming sheet metal, & easing components. Also in WHITE



Copper/Hide Wheel Nut Mallet
SKU: CA1298

Original Thor 40mm (No 2) copper/hide wheel hammer for use removing wheel spinner nuts etc.



Soft-Grip Impact Driver Set - 14 piece
SKU: IMPACTDRIVER

Reversible. Soft-grip handle with protective guard. 1/2" square drive - can be used with sockets. 13 bits.



Soldering Iron 40W (40W UK)
SKU: SOLDIRON2

General purpose, for a wide range of electrical soldering of circuits, medium-thick wires and cables.

Tools, Consumables, Accessories

Tools



Soldering Stand HD with Sponge
SKU: SOLDSTAND

Heavy duty metal base featuring reinforced spring holder. Supplied with cleaning sponge. 85 x 125mm Base



Multi-core 1mm Solder on Roll
SKU: SOLDER

20g or 100g roll of multi-core flux 1mm electrical solder 60:40 tin/lead. For electrical and electronic work.



Wire Brushes, steel or brass
SKU: WIRE

Steel/brass-plated steel wire bristle brushes for general or light cleaning. Polyurethane handle



Brass Pipe Cleaning Brushes 1/2", 3/4" & 1"
SKU: PIPEBRUSH

Corrosion-resistant brass wire bristles, galvanized steel stem. For cleaning drill holes and internal bores.



Heavy duty wire brush - 4 Row & 6 Row
SKU: WIRESTEEL

Heavy duty steel wire brush with wooden handle. Bristle length 25mm. Length 290mm. 4 row or 6 row



Spark Plug Gap Tool 0.02 - 0.1"
SKU: GAPTOOL

Coin-type tool to adjust the side wire without damaging the element Metric 0.5 - 2.55mm, imperial 0.02 - 0.1".



Spark Plug Brush Brass Bristles
SKU: SPARKBRUSH

Brass bristles and hardwood handle. For cleaning spark plugs. Length 200mm.



Deburring Tool
SKU: DEBURR

High quality rotating blade. Bayonet fitting for easy blade replacement. Removing burr from copper, aluminium & light steel pipe.



Alloy Thread Tester Plate
SKU: THREADTEST

Handy plate for identifying common threads - Metric 6, 8, 10mm; UNF 1/4", 5/16" and 3/8"; BSF 3/16", 1/4", 5/16", 3/8"; BSP 1/8", 1/4", Whitworth 1/4", 5/16", 1/2"; NPT 1/8", 1/4" & 3/8"



Ignition Spark Tester

SKU: SPARKTEST

Connects between spark plug and ignition lead to give a clear indication of ignition system function.



Braid Spreaders for -3 & -4 Hose
SKU: BRAIDSPREADER

For working with braided stainless steel hose.



Multi Cut Step Drill, 8mm Shank
SKU: DRILL2

For working with braided stainless steel hose.



Hollow Punch Set - 6 Piece
SKU: HOLSUN

Heat-treated carbon steel. Creates clean, accurate holes in rubber, leather, plastic and vinyl.



HSS Drill Set 25 Piece 1 to 13mm
SKU: DRILL1

Roll forged drill set Suitable for steel, cast iron, copper, brass, iron and plastics. 0.5mm increments.



Piston Ring Pliers
SKU: RINGPLIERS

Installs and removes piston rings from 1.2mm up to 6.4mm (1/4") without twisting. Sprung mechanism.



Glazing Tool Kit
SKU: 3240

To help fitting windscreens, side windows etc. with plastic/rubber inserts on older vehicles.



Valve Grinding Stick
SKU: GRSTICK

Small Valve Grinding Stick. Suction cups are 19mm and 22mm



Welding Magnet 100mm/13kg
SKU: WELDMAG2

Powerful welding magnet for holding workpieces securely in place at fixed angles of 45, 90 & 135°



Valve Grinding Stick
SKU: RINGCOMPRESSOR

Sprung steel band with all-steel ratchet mechanism. For easy installation of pistons into cylinders.



Puller Set - 46 piece
SKU: BALANCERPULLER

Puller set for removing flywheels, balancers and pulleys. Imperial and metric bolts.

Washer & Wiper Systems

Washer Bottles, Pumps & Accessories

We stock a full range of parts for the widely used Lucas 14W motor system. We also supply complete custom made wiper system to your specifications.



Windscreen Washer Tube

SKU: WASHER-TUBE

Clear plastic windscreen washer system tube. 6.25mm OD and 3.75mm ID. Sold by the metre.



Washer Jet Black Twin

SKU: WP7

High quality construction with brass adjustable nozzles & brass nut. 10mm high x 10mm wide.



Windscreen Washer Single Jet

SKU: 214S

Small (8mm diam), chrome plate, pipe connection 3.5mm. Equivalent to Lucas WSB136 type.



Windscreen Washer Twin Jet

SKU: 214D

Approximate 13mm diameter, pipe connection 4.5mm. Equivalent to Lucas WSB131 type.



Manual Windscreen Washer Pump

SKU: 909A

Manual push black plastic button, 80mm overall length, 42mm dia at widest point.



12v WINDSCREEN WASH PUMP

SKU: EWP23

12v universal. Equivalent to Lucas WSB100 washer pump type.



Non Return Valve for Bottle Suction Lines

SKU: WASHER-VALVE

Plastic non-return valve with push on connection for 4mm inner diameter washer tubing.



Compact Washer Bottle Complete with Bracket

SKU: WB-COMPACT

Polythene 0.5L bottle 76mm diameter and 145mm tall. Includes internal non return valve.



Reproduction WSB101 Washer Kit

SKU: WSB101

Bottle & pump assembly, Bracket & strap. Equivalent to Lucas WSB101.



Windscreen Washer Soft Bottle Kit 1Ltr

SKU: EWP16

Soft bottle & pump assembly, mounting bracket, push button switch, tube & 2x single jets.



Windscreen Washer Bottle & Pump Kit

SKU: CA1373

1.2Ltr bottle with built in 12v pump, mounting bracket. 170mm tall x 140mm wide x 70mm deep. Two single jets



Windscreen Washer Bottle & Pump Kit

SKU: CA1373L

1.6Ltr bottle, built in pump, mounting bracket. 180mm tall x 120mm wide x 100mm deep. Two single jets.



Universal Windscreen Washer Pump - 12v

SKU: WASHPUMP

Universal windscreen washer pump on mounting plate. Suitable for accessory kit part number WAKIT



Windscreen Washer Accessory Kit

SKU: WAKIT

Double washer jets, tee piece, straight connector, tube, wiring loom, push switch, clips, bracket, bolts.



Windscreen Wiper Motors

The most popular (bulkhead mounting) type still available is the Lucas 14W. This is a two speed wiper motor, with self parking. Lucas did make a 16W type but this was only used on Triumph Stags & Reliant Scimitars etc., and is no-longer available. Make sure you use the correct base pad and strap with the rubber covering (in good condition), and that the motor is not touching any part of the vehicle body to eliminate noise.

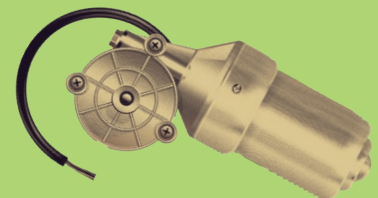

Washer & Wiper Systems

Wiper System Kits

We probably receive more technical queries about wiper systems than any other subject. See notes (overleaf) based on an article written by Tony Stafford, the founder of Stafford Vehicle Components who spent his working life in the motor industry.



Wiper System, One Wheel Box

SKU: WIPER1

One-wheel box wiper assembly. The kit comes with a 14W motor, 32 or 40 tooth wheel box (32 is the most popular), drive gear 90° to 130° (it can take a couple of attempts to get the sweep correct), nut, ferrule, pad & strap, bundy tubes (cut to length and flared) and drive rack cut to size (you need to confirm sizes, see GUIDES, the wheelbox required and degree of drive gear).

System does not include arms or blades.

This is the order form we get the most questions about, so if you are unsure about any part, please call or email us. Please give the length of the tubes in the additional information box, for example, 335mm or 6 1/4"



Wiper System, Two Wheel Box

SKU: WIPER2

Two-wheel box wiper assembly. The kit comes with 14W motor, two 32 or 40 tooth wheel boxes (32 is the most popular), drive gear 90° to 130° (it can often take a couple of attempts to get the sweep correct), nut, ferrule, pad & strap, bundy tubes (cut to length and flared), and drive rack cut to size -you need to confirm sizes, see 'GUIDES', the wheelboxes required and degree of drive gear.

Does not include arms or blades.

This is the system form we get the most questions about, so if you are unsure about any part, please call or email us. Please give the length of the tubes in the additional information box, for example, 335mm or 6 1/4"



Wiper System, Three Wheel Box

SKU: WIPER3

Three, wheel box wiper assembly. The kit comes with a 14W motor, three 32 or 40 tooth wheel boxes (32 is the most popular), drive gear 90° to 130° (it can often take a couple of attempts to get the sweep correct), nut, ferrule, pad & strap, bundy tubes (cut to length and flared) and drive rack cut to size -you need to confirm sizes, see 'GUIDES', the wheelboxes required and degree of drive gear.

Does not include arms or blades.

This is the system form we get the most questions about, so if you are unsure about any part, please call or email us. Please give the length of the tubes in the additional information box, for example, 335mm or 6 1/4"

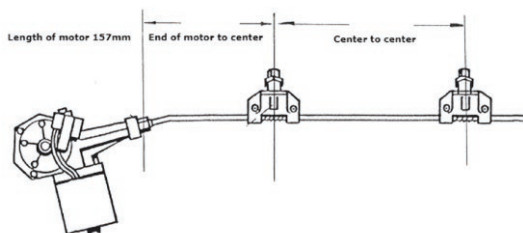

Fitting a Wiper System

Mock up the wiper system on your work bench, with wiper arms in the left or right "parked" position as required. Try to mount the motor and gearboxes in as straight a line as possible, checking that the drive cable (drive rack) will reach all the gearboxes. If you need to make a bend in the first section of bundy tube, then this should be as gentle a curve as possible.

Fit the tube to motor with nut holding the flared end. With the first gearbox in place, remove the nuts holding the gearbox together. The flared end of the bundy tube fits into the cutout when the gearbox is bolted back together. Repeat with the second (& third if fitted) gearboxes and a final short length to cover the exposed inner cable when at full extension. Finally remove the motor from its mount and refit it while feeding the well lubricated drive cable through the tubes and gearboxes.

Washer & Wiper Systems

Windscreen Wiper Guide

Drive Gear

When the new motor arrives there is no threaded ferrule to take the drive tubes or internal gear. There are several gears to fit this motor starting with the number 95 which is stamped on the top round plate. This gives the least amount of travel to the rack and wiper arms. The most travel gear is 130.

The gear ratios go up in 5's so starting with 95, 100, 105 and so on, most of these are still available. On the top of the gear plate where the number is stamped there is a drive peg welded in position. This is the only item which changes position throughout all the gears (e.g. welded in different positions on the top plate.). Obviously if this peg was welded to the centre of the plate there would be no travel at all, so the further the peg is positioned to the outer edge of the plate the more travel you get. With each gear come 2 washers and a circlip that retains the gear in the motor, always pack grease in the gear area before refitting the top cover.

Wheel Boxes

The most popular wheel box size is 32 teeth on the inner drive wheel and the ideal length of shaft from the inner face to the end of the splines is 2.5 inches. This allows for the thickness of material on fibreglass cars as the first spacer can be cut down in size allowing for varying thicknesses through the bulkhead where the wheel boxes fit. There is also a 40-tooth wheel box which will reduce the amount of wiper arm travel.

If the car has a split screen then it is quite easy to fit what was called the clapped hands system. This is by turning one of the wheel boxes through 180 degrees.

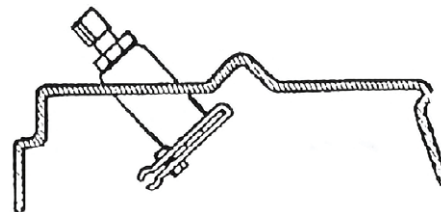

Wheelbox showing inner and outer spacer

Drive Rack

When fitting a new system it is advisable to fit a new drive rack as this is one of the items that wears, resulting in the wiper arms having too much play.

Drive or "Bundy" Tubing Sets

Bundy tube sets can be made up providing the customer supplies 2 dimensions. The first is the distance from the motor to the centre of the first wheel box hole, and the second the distance between the wheel box hole centres through the bulkhead. Obviously if it is a 3 wiper system, then there is another dimension needed. Try to avoid sharp bends in the tubing. If you have to bend the bundy tube, an easy way to form the shape is to insert the drive rack into the tube before bending. This will keep the tube the correct diameter on any of the bends (very much like a plumber bends copper piping by inserting a spring). Always grease the rack liberally before inserting into the bundy tube.

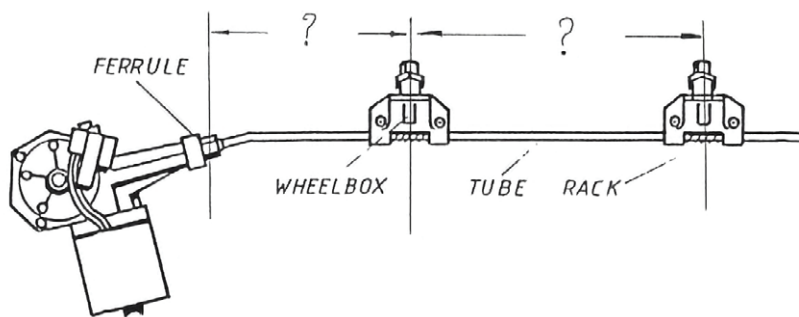

Switch

It is important that you use a correct wiper 2-speed switch. The reason for this is that when the switch is in the off position with the ignition switched on there is one connection which becomes live. This operates the parking position. If you use a non-live switch then the wipers would stop whenever the switch was switched off.



Lucas Wiper Switch Part No. 35927

Terminal Connections

- 4. 1st speed red/green light
- 8. Park brown/light green (linked to no.4 when switch is on off position)
- 6. Ignition live green
- 2. 2nd Speed blue/light green

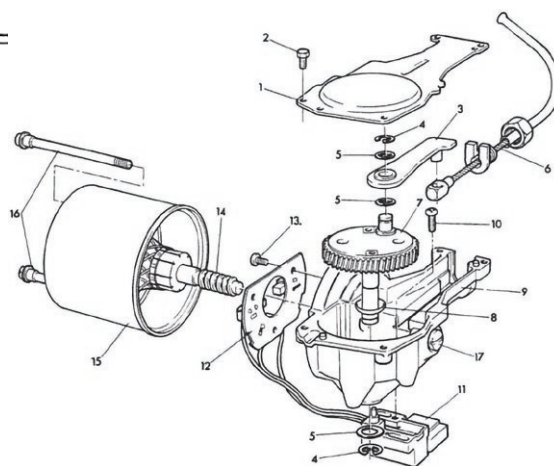

- | | |
|-----------------------------|------------------------|
| 1. Gearbox cover | 9. Gearbox |
| 2. Screw for cover | 10. Limit switch screw |
| 3. Connecting Rod | 11. Limit switch |
| 4. Circlip | 12. Brush gear |
| 5. Washers | 13. Screw for brushes |
| 6. Flexible wiper drive | 14. Armature |
| 7. Gear wheel with crankpin | 15. Yoke |
| 8. Dished washer | 16. Bolts |
| | 17. Thrust screw |

Washer & Wiper Systems

Windscreen Wiper Guide



Wiper Systems Introduction

SVC wiper systems are all bespoke and made to customer specifications. They have a universal application and can be fitted to anything with a windscreen. Cars/lorries/boats etc.

Customers will need to calculate the sweep angle and distanced between the motor and wheel boxes before placing an order.

Sweep angle is determined by the drive gear / wheel box combination

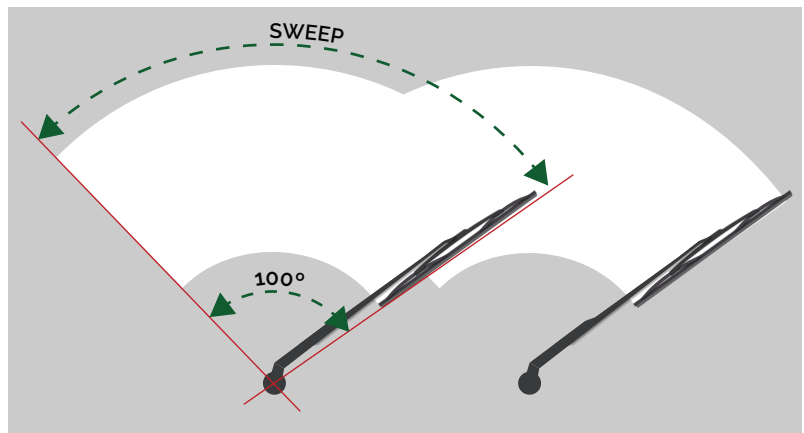

Wheel Boxes

Wheel boxes all come with a spacer, rubber washer and a chrome bezel.

32 Tooth – Most common. 64mm shaft length. The drive gear angle will match the final sweep angle of the wiper arm if you use this wheel box.

40 tooth – 64mm shaft length. Larger wheel box base. The drive gear angle will be reduced by this wheel box. So the final sweep will be less than the drive gear angle.

22 tooth – 64mm shaft length. Smaller wheel box base. The drive gear angle will be increased by this wheel box. So the final sweep will be greater than the drive gear angle.

'Mini' wheel box – This is the same as a 32 tooth wheel box. However, it has a shorter 49mm shaft length. Used on classic Minis.

Drive Gear

Available in sizes 90, 95, 100, 105, 110, 115, 120, 125 and 130°.

With a 32 tooth wheel box, the drive gear angle will match the final wiper arm sweep.

Creating The Correct Final Wiper Arm Sweep

A 32 tooth wheel box with a 120° gear will produce a system with a wiper arm sweep of 120°.

So for any sweep between 90° and 130°, use a 32 tooth wheel box with the corresponding angle drive gear

For a final sweep greater than 130°, the system will need a 22 tooth wheel box, and a suitable drive gear. A 115° drive gear with a 22 tooth box gives 175° of final wiper arm sweep.

A 90° gear with a 40 tooth box will give 55° of final wiper arm sweep.



32 Tooth Wheelbox



32 Tooth Wheelbox showing gear



Selection of drive gears, 90°, 110° & 130°



Exchange

Customers may exchange wheel boxes/drive gears to find their perfect setup – we only ask for payment for exchange postage (unless the combination/angle was from our calculation)

Washer & Wiper Systems

Wiper Motors

Wiper motors for mounting to windscreen frames and onto the engine bulkhead. 6 volt and 12 volt versions with self-parking variants for convenience.



Wiper Motor Lucas CWX Type 6 Volt - Windscreen Frame

SKU: 656

Equivalent to the Lucas type CW1/CWX as fitted to many early cars. Only 6v currently available - which can be used on 12v vehicles fitted with a DC12V to DC6V step-down regulator. Re-manufactured item, incorporating switch and 'wiper park' facility. Black crackle finish.

Due to known problems with original units, we spent considerable time in correcting the erratic starting issue, by having a different new armature made amongst other small modifications.

Body size approx 90mm wide x 56mm high x 68mm deep. Drive shaft approx 5mm, mounting studs at 38mm centres. Approx sweep of 125 degrees.



Wiper Motor 12 Volt - Windscreen Mounted

SKU: 479.12

Powerful, robust, silent 12 volt wiper motor with 110 degree sweep, which will drive any wiper set. Mounting hole 10mm, shaft size 6mm, matt black plastic cover with switch built in. Shaft length easily shortened. As mounted with the drive upper the electrical connections are on the right side viewed from inside the vehicle. Please note: the metric size shaft will require turning to fit the imperial size wiper arms we offer.

Body approx 80mm wide x 52mm high x 76mm deep. Mounting hole 10mm, shaft size 6mm. Sweep of 110 degrees.



Wiper Motor - Windscreen Mounted 6v or 12v

SKU: 386

Practical modern wiper motor for continual use, 6 volt or 12 volt. Dull black plastic cover, switch with 'auto-park'. central drive offtake (6mm), requires 8.7mm shaft hole through screen, with two stabilising mounting points. Length of thread approx 60mm.

Please note that this motor has a 6mm shaft, all our shaft fitting wiper arms are for imperial sizes. Insertion of thin shim material could be required to get a tight fit.

Body approx 89mm deep overall including switch. Oscillating 110 degree sweep.



Wiper Motor - Windscreen Mounted 6v or 12v CWX

SKU: 386.6-CWX & 386.12-CWX

Practical modern wiper motor for continual use, 6 volt or 12 volt. Dull black plastic cover, switch with 'auto-park'. central drive offtake (6mm), requires 8.7mm shaft hole through screen. Length of thread approx 60mm.

Front plate modified with two mounting studs at 38mm centres either side of the drive, similar to the Lucas CWX motor mounting arrangement.

Body approx 89mm deep overall including switch. Oscillating 110 degree sweep.

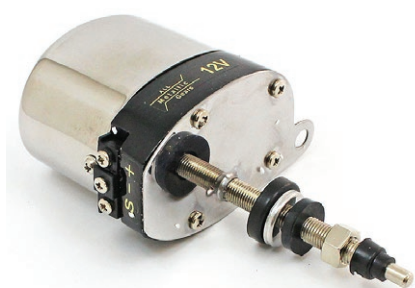

Wiper Motor - Self Park 12v Windscreen Mounted

SKU: CA292

Practical modern wiper motor for continual use 12 volt. Polished stainless steel cover, will 'auto-park' to one side. Central drive offtake (6mm), requires 9.0mm shaft hole through screen, with one stabilising mounting point approx. 43mm out from the mounting shaft. Body approx 56mm x 80mm wide x 77mm deep, oscillating 90 degree sweep. Outer shaft approx 61mm long, inner shaft approx 78mm which can be cut shorter if required. This unit requires a separate switch.

Body approx 56mm x 80mm wide x 77mm deep. Oscillating 90 degree sweep.



LRW110 14w 2 Speed Wiper Motor

SKU: LRW110

Reproduction twin speed 14W Wiper Motor equivalent to Lucas LRW110 (GXE7708).

As fitted to the MGB from 1967, the Sprite/Midget with late 1275 engines and all 1500 engines and the Triumph Spitfire from about 1980, also Land rover, Morgan, Vauxhall, Hillman, Austin and others.

Body approx 165mm x 150 x 89mm. 1.7Kg. Oscillating 130 degree sweep.

Washer & Wiper Systems

Wiper System Components



**Mini Wheelbox (Short)
For LRW110 14w Motor**
SKU: LU72872

To fit Lucas type 14w motor (LRW110) Shaft 64mm long. With inner spacer, oval washer, chromed outer spacer with nut. For Classic Mini.



**Wiper Wheelbox for
LRW110 14w - 22 Teeth**
SKU: LU72744

Shaft 64mm long including spline. Supplied complete inner spacer, oval washer, chromed outer spacer with nut 22 teeth



**Wiper Wheelbox for
LRW110 14w - 32 Teeth**
SKU: LU72879

To fit Lucas type LRW110 14w. Shaft 64mm long including spline. Supplied complete inner spacer, oval washer, chromed outer spacer, nut.



**Wiper Wheelbox for
LRW110 14w - 40 Teeth**
SKU: LU72866

Shaft 64mm long including spline. Supplied complete inner spacer, oval washer, chromed outer spacer with nut.



**Wheelbox Nut -
6-Sided**
SKU: 6SN

Wheelbox shaft nut - 6-sided -13/16" across the flats.



**Wiper Park Switch
for LRW110 14w**
SKU: LUB101

Clip on parking switch for Lucas type 14W. Fitted to the MGB, the Sprite/Midget with 1275 & 1500 engines and the Triumph Spitfire from 1980.



**Wheel Box Chrome
Outer Bezel**
SKU: LU72879BEZ

Wheel box chrome outer bezel with rubber gasket.



**Wheelbox Rubber
Gasket**
SKU: wheelbox-rubber

Wheelbox rubber gasket, fits under the chrome trim.

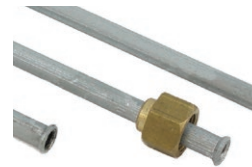

**Bundy Tube Length -
Single Flare & Nut**
SKU: 60600539

Ring to order specific lengths. Price per nearest meter. 8mm o/d.



**Rubber Grommet for
5/16" Bundy Tube**
SKU: BUNDY-GROMMET

Seals on bundy tube outer diameter, to provide a seal on 34mm panel hole.



**LRW110 14w WIPER
Drive Gear Options**
SKU: LULRW

LRW110 14W drive gear. From 90 degree to 130 degree in 5 deg. Increments.

Wiper Movement

130 degrees

125 degrees

120 degrees

115 degrees

110 degrees

105 degrees

100 degrees

95 degrees

90 degrees



**Ferrule For Wiper
Motors**
SKU: 54704623

Ferrule for LRW110 wiper motors.



**Drive Rack, for LRW110
14w Wiper System**
SKU: LU743251

LRW110 14W Wiper Drive Rack, available cut to size or at uncut 15m approx. length.



**Insulated Strap & Pad
for Wiper Motor**
SKU: WMS&P

Clamps the LRW110 14w Wiper Motor with rubber to reduce the noise transmitted into the car.



**Wiper Motor Connector
Kit**
SKU: WMK

Wiper motor connector kit consists of one plug and 5 terminals. See website guides for wiring diagram.



**Brush & Pad Set for The
14w Wiper Motor**
SKU: 60270012

Brush & Mounting plate assembly for the Lucas 14W twin speed wiper motor.



**Wiper Arm Converter
(Shaft To Spline)**
SKU: CA395

Adaptor to fit a spline shaft wiper arm on to a motor shaft secures with pinch bolt.



**2 Speed Rotary Wiper
Switch**
SKU: 2SWS

Wiper switch 2 speed for self parking motors



**2 Speed Wiper
Toggle Switch**
SKU: 35927

With park position. Equivalent to Lucas part numbers 35927, BHA4786, 575A.

Washer & Wiper Systems

Wiper Arms & Blades

With 3,600 wipes per hour, moving water and dirt, unfortunately wiper blades usually fail when you need them most. It is recommended to replace wiper blades yearly before the rubber begins to perish. Possibly the easiest job on the car!

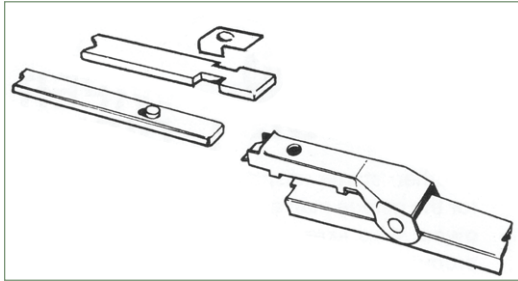

5mm Bayonet Type Arms & Blades

Typical fitting for post 1960 vehicles with curved windscreens. The lower bayonet arm is more common.

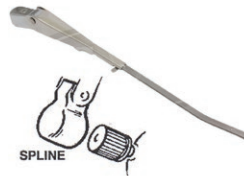

5.2mm Bayonet Wiper Arm, Spline Fitting

SKU: 830

Stainless steel wiper arm for spline fitting. Adjustable in length from 170mm to 300mm long



5.2mm Windscreen Wiper Arm for 1/4" Shaft

SKU: CA738

For 1/4" motor shaft. Strong spring to pull blade onto glass. Adjustable from short 130mm to 270mm long.



Wiper Blade, 5.2mm Bayonet, Curved Screen

SKU: 213

Stainless steel back with sprung rubber wiper. 8", 9", 10", 11" & 12" blades available.

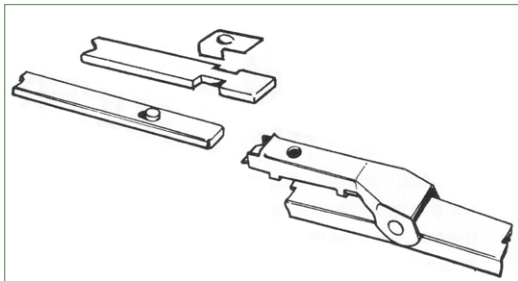

7mm Bayonet Type Arms & Blades

Typical fitting for post 1960 vehicles with curved windscreens. The lower bayonet arm is more common.

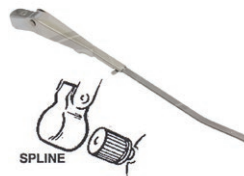

7mm Bayonet Wiper Arm, Spline Fitting

SKU: 830

Stainless steel wiper arm for spline fitting (13 - 14.8mm). Adjustable in length from 170mm to 300mm long



Wiper Blade, 7mm Bayonet, Curved Screen

SKU: 213

Stainless steel back with sprung rubber wiper. 10", 11", 12", 13", 14" & 15" blades available.



Wiper Blade, 7mm Bayonet, Curved Screen

SKU: 213

Stainless steel back with sprung rubber wiper. 10", 11", 12", 13", 14" & 15" blades available.

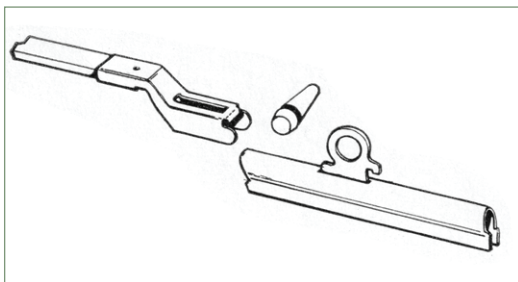

Slot & Peg Type Arms & Blades

Typical fitting for vehicles with flat windscreens. A rubber peg secures the wiper blade.



Slot End Arms, Spline or Shaft Fitments

SKU: 477, 830S, CA738S

Stainless steel & Chrome wiper arms for flat screens. Various types inc. correct Trico pattern.



Wiper Blade for Flat Screen - Slot Type

SKU: 370blade

Stainless steel back rubber wiper. 8" or 9" (can be cut to shorten) Use rubber peg to secure



Wiper Blade Pegs for Slot Type Blade

SKU: 372

Rubber peg to secure slot type blade to arm, and version with triangle flap.

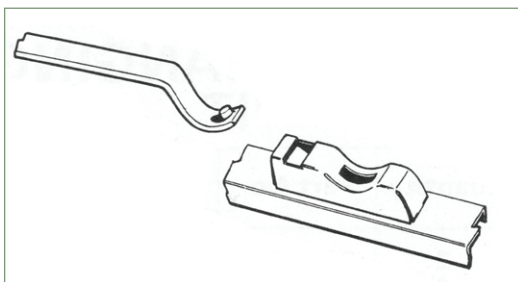

Wrist/Spoon Type Arms & Blades

Hook fitting usually found on vehicles with curved windscreens prior to 1960.



Wiper Blade, Wrist Fitting, Curved Screen

SKU: 585

Stainless steel & Chrome wiper arms, Shaft & spline fitments & Trico pattern. Adjustable lengths.



Wiper Blade, Wrist Fitting, Curved Screen

SKU: 697

Stainless steel back with sprung rubber wiper. 8", 9", 10", 11" & 12" blades available.



Wiper Blade, Wrist Fitting for Flat Screen

SKU: 478

Wrist type blade for flat screen as Trico P1000, stainless backed blade. 255mm long (can be cut).

Water Cooling

Complete Electric Cooling Fan Kits

High quality cooling fan kits tailor made for a number of popular classics by Austin Healey, Jaguar, MG, Triumph and Daimler. Kits come complete with all necessary fittings and installation instructions. Improve MPG and reliability.



MGB Chrome Bumper Model 1962-76 Cooling Fan Kit

SKU: B-MGB 62-76

This is a tailor-made cooling fan kit for all MGB chrome bumper cars 1962-76. The kit comes with all fixings and fittings. Easy to install with basic hand tools and without any permanent modifications to your car.

For Negative Earth Kit Contains:

- 10" High Power Blowing fan
- Laser cut aluminium fan mounting brackets
- 28mm Revotec Electronic fan controller
- Top hose replacement kit
- Earth wire kit
- Bolts & fittings



Austin Healey 3000 Cooling Fan Kit
SKU: B-AH3000

This is a tailor-made cooling fan kit for all Austin Healey 3000. The kit comes with all fixings and fittings.



Classic Mini Cooling Fan Kit
SKU: B-MINI59-97

This is a tailor-made cooling fan kit for Classic Mini, side mounted radiator. The kit comes with all fixings and fittings.



Jaguar MkII Cooling Fan Kit
SKU: B-JMKII

This is a tailor-made cooling fan kit for all Jaguar MkII. The kit comes with all fixings and fittings.



Jaguar XK150 Cooling Fan Kit
SKU: B-JXK150

This is a tailor-made cooling fan kit for all Jaguar XK150. The kit comes with all fixings and fittings.



Jaguar E-Type - Series 1 3.8/4.2 Litre. Fan Kit
SKU: B-JET-S1

This is a tailor-made cooling fan kit for all Jaguar E-Type Series 1, 3.8/4.2 Litre. The kit comes with all fixings and fittings.



Jaguar E-Type - Series 2 4.2 Litre Fan Kit
SKU: B-JET-S2

This is a tailor-made cooling fan kit for all Jaguar E-Type Series 2 4.2 Litre. The kit comes with all fixings and fittings.



Jaguar E-Type - Series 3, Cooling Fan Kit
SKU: B-JET-S3

This is a tailor-made cooling fan kit for all Jaguar E-Type Series 3. The kit comes with all fixings and fittings.



MG Midget & Austin Healey Sprite Fan Kit
SKU: B-SMG VERT

This is a tailor-made cooling fan kit for MG Midget & Austin Healey vertical flow radiator. The kit comes with all fixings and fittings.



MG Midget & Austin Healey Sprite Fan Kit
SKU: B-SMG 1275

This is a tailor-made cooling fan kit for MG Midget & Austin Healey X-Flow 1275cc. The kit comes with all fixings and fittings.



MG Midget & Austin Healey Sprite 1500cc Fan Kit
SKU: B-SMG 1500

This is a tailor-made cooling fan kit for MG Midget & Austin Healey 1500cc. The kit comes with all fixings and fittings.

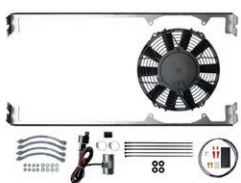

Morris Minor Cooling Fan Kit
SKU: B-MM

This is a tailor-made cooling fan kit for Morris Minor. The kit comes with all fixings and fittings.



Triumph Herald Cooling Fan Kit
SKU: B-TR-HD

This is a tailor-made cooling fan kit for Triumph Herald. The kit comes with all fixings and fittings.



Triumph TR2, TR3 & TR4 Cooling Fan Kit
SKU: B-TR2-3-4

This is a tailor-made cooling fan kit for Triumph TR2, TR3 & TR4. The kit comes with all fixings and fittings.



Triumph TR5 & TR6 Cooling Fan Kit
SKU: B-TR5-6

This is a tailor-made cooling fan kit for Triumph TR5 & TR6. The kit comes with all fixings and fittings.

Other Car Kits Available

Daimler Dart

MGA

MGB Rubber Bumper
MGB V8

Triumph TR4A

Triumph GT6

Triumph Stag

Water Cooling

Electric Radiator Cooling Fans



Choosing an Electric Fan

Keeping your engine cool is essential, but many classics struggle sitting at idle in heavy traffic. Electric fans can give you all the airflow through the radiator that is needed, as well as a boost in power and fuel economy, as they are not driven off the crankshaft. They can also continue to cool the car after the engine is stopped.



Diameter & Shroud

Always cover as much of the radiator core as possible. Remove the existing fan & shroud to measure the space available. Some large engines will have space for 2 fans. You may need to make your own shroud to get maximum airflow through the radiator core.

Blow or Pull?

Fans can either push/blow air through the radiator from in front, or pull/suck from behind. Generally a puller will have more cooling power, but the decision to mount in front or behind the radiator will usually be determined by available space. Make sure you order the correct fan version - Blowing or Suction - they are not interchangeable.

Straight or Curved?

Airflow versus noise. Straight blades move more air, but at larger sizes can be noisy. Curved blades are quieter, but less powerful. Manufacturers also optimise blade shape for blow or pull.

Wiring

Always use a relay, big fans can have a high current draw as they start each time.

Performance

Fans are rated by cubic feet of air per minute (CFM). As a starting point a 4-cylinder engine needs about 1,250 CFM and a 6-cylinder engine needs 2,000 CFM. Obviously tuning, super-chargers, weather, etc. will effect this requirement.



SVC Budget 10" Fan



Comex Performance 9" Fan

SKU No.	Size	Details
BUD10	10"	SVC Budget Fan 276mm x 290mm
BUD12	12"	SVC Budget Fan 295mm x 318mm
COMEX9	9"	Performance (B) 1030 CFM (S) 1010 CFM
COMEX10	10"	Performance (B) 1240 CFM (S) 1440 CFM
CONEX12	12"	Performance (B) 1860 CFM (S) 1580 CFM
COMEX14	14"	Performance (B) 2010 CFM (S) 2060 CFM
COMEX15	15"	Performance (B) 2920 CFM (S) 3030 CFM

Comex Fans

Comex fans are perhaps the best fans available in the world at the moment, we think so at least. Made to fit straight to the radiator and give top performance combined with a long life, they are great for all types of cars.

Comex fans feature high quality component parts and use dedicated suction or blower blades to maximise airflow. The fans have a wide range of applications - suitable for off-road vehicles, classic cars, race prepared vehicles, coaches, and motor homes.

CFM figures are measured at 12v DC and 0.2"/5mm static pressure. The size relates to the diameter of the blade rather than overall housing size. All housings have four integral 6.5mm mounting holes with other mounting options available.



Fan Pull Through Radiator Fitting Kit
SKU: FPK01

Pull Through Kits are an ideal quick fix solutions. Perfect for motorsport applications or for fans under 12".



Thermostatic Fan Switch
SKU: TURMSW

Simple fitting switch which goes into the top hose. This switch kit is adjustable to turn your fan on between 60 and 120 degrees C.



Revotec Electronic Fan Controller
SKU: EFC

Fits directly into a radiator top or bottom hose for direct water contact. Hose ID 25mm to 45mm. Positive & negative earth vehicles.



Fan Installation Kit
SKU: COMINST

Perfect when installing without a Revotec Electronic Fan Controller. Complete with relay, loom, Fan Earth Kit, & Fan Pull Through Kit.



Comex Fan Earth Kit
SKU: COMEK

The simple solution to earthing a COMEX fan - the kit contains everything needed.

Water Cooling

Cooling Fan Installation Accessories & Hose

A range of universal aluminium fan brackets, flush fan mounts, feet and installation kits for our 9, 10, 12, 14 and 15" Comex fans.



Universal Aluminium Fan Brackets 9" - 15"

SKU: Various

Perfect for securely mounting a fan to the radiator. Made from laser cut aluminium to suit the stated fan size.



Fan Flush Mount - Pair 9" - 15"

SKU: Various

Ideal for sitting a fan flush onto a radiator core with no damage. Each kit is supplied with 2x Flush Mounts, 4x M6 Nyloc Nuts and washers.



Fan Mounting Foot Types H & L COMEX

SKU: Foot

Supplied as each. Various types to suit the fan diameters. Supplied with Bolt, Nyloc Nut & Washer.



Self Sealing Fitting - 3/8" BSP

SKU: SELFSEAL1

This kit comprises a unique self-sealing fitting, machined nut, washer, O ring and cutter (as pictured) - creating a 3/8 BSP female tapping point. Suitable for connection to virtually any silicone, rubber or plastic hose and will even work on semi-rigid plastic and metal. Pressure tested to 4bar. Material - Aluminium. Each kit contains a hole punch, a self sealing insert, a self sealing washer, a threaded nut and O-ring.

Engineered to solve the problem of teeing into water and air hoses. This unique design forms a perfect seal and will even work on semi rigid plastic and metal. For fitting in pipe diameters of approx 32mm upwards.



Fan Override Switch - Smiths Style Toggle

SKU: FANOR2

For use with a Revotec Fan Controller enabling the fan to be manually controlled either On or Automatic.



Electronic Fan Controller - 3/8" BSP

SKU: EFC3/8BSPNE

Negative Earth Housing. Screws directly into radiator with thread. With relay & Instructions



Fan Override 3 Way Switch - Rotary

SKU: FANOR1

For use with a Revotec Fan Controller enabling the fan to be manually controlled either On, Off or Automatic. Perfect for 4X4 applications.



Super Flexible Radiator Hose

SKU: FRH

Super Flexible® hose from 7/8" to 2" bore made from reinforced EPDM rubber with synthetic textile cover. Maximum working pressure 150psi. Temperature range -40degC to +120degC. Black heat resistant EPDM rubber reinforcement, synthetic textile cover. Heat, weather and ozone resistant.

- 7/8" Internal Diameter
- 1" Internal Diameter
- 1 1/8" Internal Diameter
- 1 1/4" Internal Diameter
- 1 1/2" Internal Diameter
- 1 3/4" Internal Diameter
- 2" Internal Diameter



Black Reinforced Radiator Hose

SKU: 519

Straight lengths of reinforced black hose for radiators etc. we supply pieces of 0.5 or 1 metre long, with internal bore sizes 13mm through to 76mm. Wall thickness vary but approx 4mm minimum. Available in the following bore sizes.

- 13mm Bore
- 16mm Bore
- 19mm Bore
- 22mm Bore
- 25mm Bore
- 28mm Bore
- 32mm Bore
- 35mm Bore
- 38mm Bore
- 42mm Bore
- 45mm Bore
- 48mm Bore
- 51mm Bore
- 54mm Bore
- 57mm Bore
- 60mm Bore
- 63mm Bore
- 70mm Bore
- 76mm Bore



Pressure Cap Header Tank Or Radiator

SKU: PCAP

Stainless Steel. The pressure valve consists of a spring-loaded disc that contacts the filler neck to form a seal. At higher temperatures pressure increases so if the engine overheats and the pressure exceeds the cap rating, the pressure valve opens, forcing coolant out of the overflow tube. 7 pressure options.

SKU	Pressure
PCAP	0 psi
PCAP4	4 psi
PCAP7	7 psi
PCAP10	10 psi
PCAP13	13 psi
PCAP15	15 psi
PCAP20	20 psi

Wiring

Wiring Looms & Harness Sleeving

All our wiring looms are made in England to the very highest standard using British standard coloured wires. They are designed for universal fitting and we have sold them for a wide range of cars including 1930's special body Austin 7's, Hot Rods and all types of Kit Car. Supplied with instructions.



Front Engine Modular Loom (SVC-4)

SKU: LOOMFR

Front-engine modular wiring loom - designed for universal usage. If you are a novice at wiring then the modular loom is made to make it as easy as possible. Also if you intend to change any part of your car in the future this is the loom to go for. Designed for front engine cars.



The Basic Front Engine Loom (SVC-2)

SKU: LOOMBA

The basic loom is made for universal application and comes with relays and fuses. This loom is made to the highest quality in the UK. The wires come with no terminals fitted so they can be finished to your specific requirements. A full wiring information sheet is supplied and the loom is clearly labelled for ease of fitting.



Mid Or Rear Engine Modular Loom (SVC-3)

SKU: LOOMRE

The rear engine modular loom is designed for universal application. If you are a novice at wiring then the modular loom is made to make it as easy as possible. If you intend to change any part of your car in the future this is the loom to go for. Designed for mid and rear engine cars.

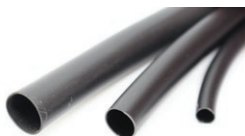

Wiring Harness Sleeving - Black PVC

SKU: 376

0.5mm wall thickness. Supplied in 5 metre or 25 metre rolls. Bore sizes - 5mm, 7mm, 9mm and 11mm.



Spiral Wrap Cable Tidy Black Polythene

SKU: SPIRAL

Spiral wrap for cable tidy. 4 Sizes to cover 4mm to 70mm Price per metre.



Expandable Braided Cable Sleeving

SKU: HRS

Flame retardant expandable polyester braided cable sleeve offering durable abrasion resistance in a wide range of applications.



Wiring Harness Sleeving Bituminised Fabric

SKU: 344

Popular traditional black wiring harness sleeve. Sizes 6 - 12mm bore (approx)



Fabric Loom Tape, Fleece

SKU: PV538

Traditional self adhesive fleece loom tape used for wrapping applications of vehicles. Width 19mm Length 25 meters



Metal Conduit Sleeving - Galvanised

SKU: CONDUIT

Galvanised steel flexible metal conduit used for sheathing cables to lamps etc. Supplied in metres, cut off roll.



Metal Conduit Sleeving - Chrome & Nickel

SKU: CONDUIT

Chrome, Nickel plated or Stainless steel flexible metal conduit used for sheathing cables to lamps etc. Supplied in 1.5m lengths.



Metal Conduit - End Fittings & Connectors

SKU: CONDUIT

Various threaded and plain end fittings for most sizes of metal conduit cable sleeving.

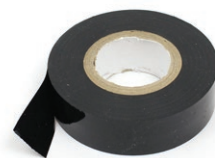

PVC tape, Non-Adhesive Black 20m

SKU: CA81-BLACK

Non-adhesive PVC harness tape for rebinding wiring harnesses. Roll 20m x 19mm.



PVC tape, Non-Adhesive Grey 20m

SKU: CA81-GREY

As CA81-BLACK, stretch slightly as it is wrapped around the cable, and the tape will grip to itself.

A range of cable suitable for 6v, 12v and 24v vehicle electrics. Our range includes traditional single core PVC cable, thin wall single core PVC cable, multi-core cables, earthing braid and traditional looking cotton-braided cable.

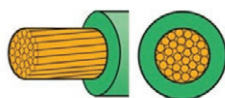
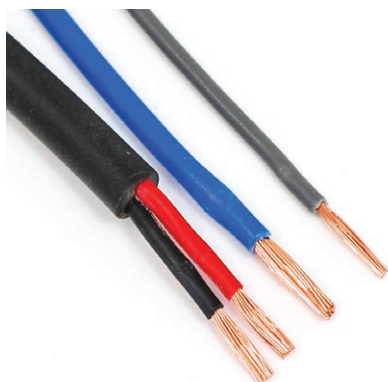

Single Core Standard PVC Cable

SKU: 1001, 496, 510, 512, 1003

PVC insulated, conductors of stranded copper wire. This type of cable was original equipment on vehicles until recently. Thinwall cable is now fitted on most new vehicles.

Item	SKU	Spec	Application
5.75 Amp	1001	9/0.30	Light duty side, tail lamp, indicator, sensors
8 Amp	496	14/0.30	Side, tail lamps, indicators, fog lamps & general wiring
16 Amp	510	28/0.30	Head lamps, wipers, screen heaters, fuel pump
27 Amp	512	44/0.30	Charging circuits & main feeds
35 Amp	1003	65/0.30	Heavy duty charging circuits & alternator feeds.



Cable Specification

All cables are made of multiple strands of copper wire. These strands are generally 0.20 or 0.30mm in diameter, with the number of strands relating to the current carrying capacity. An 8 Amp 14/0.30 cable has 14 strands of 0.30 wire with a continuous capacity of 8 Amps.

Cable Size

Amps = Watts divided by Volts.
Example: a pair of 60w headlamps gives us $120w \div 12v = 10$ Amps, so a 16 Amp cable would be ideal giving a safety margin.



Standard PVC Cable-Twin Flat

SKU: 1002, 497, 511, 914P

TWIN CORE, multistrand 5.75, 8, 16 & 27 Amp. Ideal for running to spotlights, etc.



Standard PVC Cable Triple

SKU: 498, 849P

TRIPLE CORE, multistrand 8 & 16 Amp. Ideal for running to headlights, etc.



Standard PVC Cable Quad 8 Amp

SKU: 499

QUAD CORE, multistrand 8 Amp. Ideal for running to rear light cluster, etc.



Thin Wall Cable Round Single Core

SKU: 1004, 1005

SINGLE CORE. Lower weight and volume than standard cable. Good resistance to abrasion, fuel & oils. 14 & 25 Amp.



Thin Wall PVC Cable-Twin Core Round

SKU: 1006, 1007

TWIN CORE, multistrand 14 & 25 Amp. Lower weight and volume than standard cable.



Thin Wall PVC Cable-Triple Round

SKU: 1008

TRIPLE CORE, multistrand 14 Amp. (3 x 24/0.20) Lower weight and volume than standard cable.



Thin Wall PVC Cable-Quad Round

SKU: 1009

QUAD CORE, multistrand 14 Amp. (4 x 24/0.20) Lower weight and volume than standard cable.

Cotton Braided Cable

An authentic cable for vintage and classic cars. The multi-strand copper core has a modern PVC insulation layer before the braided cotton covering. The cable is then lacquered to protect the fabric.

The finished cable looks identical to the period original but with the reliable electrical and mechanical properties of a modern auto wiring cable. The best of both worlds.



Cotton Braided Automotive Wire Cable

SKU: 608, 609, 610

Modern PVC insulation layer under the cotton braiding. Huge range of colours in 8, 16 and 27 Amp sizes.



Cotton Braid Cable - Twin

SKU: 843, 844

TWIN CORE, multistrand 8 Amp or 16 Amp capacity. Modern cable in a traditional outer sleeve.

Wiring

Connectors & Terminals

A reliable and practical wiring loom needs good multi-pin connectors at major junctions (to doors, dashboard, etc.) as well as to components. If the joint is exposed, then waterproof SuperSeal connectors are a great investment. The "Lego" multiblock type connectors are great for test wiring a loom before final assembly.



Snap Terminal Bullet Connectors

SKU: 558 & 559

Single & Double snap connectors supplied with solder type nipples



Basic Nylon Connector Blocks with Spade Pins

SKU: BAT

Quick release 2-part nylon connector housing/locking terminal block. 1 to 8 way. Spade type pins



Locking Wiring Connector Assembly

SKU: LAT

Quick-release 2 part locking wiring terminal - complete with pins. 1 to 15 way. Compact round pins.



Flexible Cable Connector Strips

SKU: FCCS

5, 10, 15 or 30 Amp sizes. Connector block with 12 pairs of terminals.



Superseal Replacement Pins & Seals

SKU: SST & SSSY

Loose Male & Female Terminals & new seals. Change wiring or reuse a Superseal connector.



Superseal Crimping Tool

SKU: TT59

Ratchet action ensures correct pressure is applied - adjustable. The best option for reliable and consistent Superseal crimps.

SuperSeal Connectors

SKU: SS1 to SS6

'Superseal' connectors for applications where a waterproof joint is required - IP67 seal rating. Highly recommended for motorcycles and off-road vehicles. These excellent connectors are suitable for cable sizes from 0.5 to 1.5mm².

Each kit includes male and female housings, terminals and seals. For optimum results the Superseal Crimping Tool is recommended. Replacement male pins, female sockets and silicon rubber seals are also available to re-use the connectors.

1, 2, 3, 4, 5 or 6 way versions are available.



Electrical Terminal Bullet End

SKU: 560

Solder type nipples for snap connector. 4.75mm diameter. Packet of 10 pieces.



6.3mm Non Insulated Spade Terminal

SKU: BATF1 & BATM1

Brass terminal with locking notch. As used in nylon connector housings BAT1 to 8.



Non Insulated Pin Terminal

SKU: LATF1 & LATM1

Loose Terminals suitable for cable sizes 0.5 to 2.5mm². Sold in packs of 10. As used in LAT2 to 15



Pre Insulated Crimp Ring Terminals

SKU: RITER & RITEB

RED suitable for 16/0.20 to 21/0.30. BLUE suitable for 21/0.30 to 35/0.30 cable.



Partially insulated FEMALE 6.3mm spade

SKU: PISPF

High quality PARTIALLY pre-insulated FEMALE spade terminals



Ross Courtney Wiring Terminal

SKU: 721

Traditional Ross Courtney type wire end terminal (post terminal), pronged cup and washer two part terminal in self colour brass.



Insulation Boot For 6.3mm Female Terminal

SKU: TNIB63

Clear soft plastic boot for 6.3mm Non Insulated terminals suitable for cable sizes 0.65 to 1.5mm².



6.3mm Non Insulated Female Spade Terminal

SKU: TNIF63

Suitable for cable sizes 0.75 to 2.0mm². Sold in packs of 10. For LUCAR 6.3mm spade connections.



Partially Insulated M/F Piggyback

SKU: PISPP

RED suitable for 16/0.20 to 21/0.30. BLUE suitable for 21/0.30 to 35/0.30 cable.



Pre Insulated Butt Terminal

SKU: BUTE

High quality pre-insulated butt terminals suitable for use with standard automotive cables.

Wiring

Battery Cable, Earth Straps & Tools

Heavy duty battery cable and earthing straps. A range of electrical crimping tools, from the basic to professional. Once you have used a high quality wire stripper and crimper you will never look back!



Battery Cable PVC Covered 160amp

SKU: 513

37/0.90 160 ampere black plastic/PVC battery cable.



Battery Cotton Braid Cable 170amp

SKU: 801

Black cotton braid (outer) battery cable, low lacquer finish, 170 amp capacity, 10.75mm approx diameter.



Battery Cotton Braid Cable 300amp

SKU: 801A

Black cotton braid (outer) 300 amp capacity, 13mm approx diameter. 6 volt systems suffer voltage drop and should use this heavier cable.



Braided Earthing Cable - Round

SKU: CA876

Round braided earthing cable (tinned copper) 260 ampere. Not insulated.



Battery Earth Strap - Flat

SKU: 828

Flat tinned copper braid cable 19mm wide by 3mm thick. Not insulated.



Battery Lead/Earth Terminal End

SKU: 556

Solder type end fixing terminal for usual 160amp battery lead/cable, fixing hole 8mm, cable inlet 8mm



Battery Solderless Terminal POS

SKU: 555-POS

Solderless battery terminal, round post, Marked P +



Battery Solderless Terminal NEG

SKU: 555-NEG

Solderless battery terminal, round post, Marked N -



Braided Earth Strap 9" with End Terminals

SKU: EARTH1

Braided earth strap - tin plated copper. Ring 8mm end connections. 9" (225mm) long



Braided Earth Strap 18" with End Terminals

SKU: EARTH2

Braided earth strap - tin plated copper. Ring 8mm end connections. 18" (450mm) long



Snap Connector Pliers Tool

SKU: 0.004.00

Plier tool for inserting bullet connector nipples into pre insulated terminals and connectors including 558 & 559.



Wire Stripper, Self-Adjusting

SKU: TT47

Cables 0.5mm² - 6.0mm². Adjustable stop for consistency in wire strip lengths plus a cable cutter.



Basic Crimping Tool

SKU: TT301

Suitable for the full range of pre insulated terminals. Also features a cable cutter and wire stripper.



Crimping Tool Un-Insulated Terminals

SKU: TT71

Compact, robust crimping tool suitable for a variety of non insulated terminals. With cable cutter and spring return.



Crimping Tool for Brass Bullets

SKU: 0-004-50

Crimping tool for brass bullet connectors.



Ratchet Tool for Pre-Insulated Terminals

SKU: 0-702-50

Heavy duty crimping tool for pre insulated terminals and heat shrink pre insulated terminals.



Ratchet Tool for Un-Insulated Terminals

SKU: 0-703-50

Ratchet crimping tool suitable for a variety of non insulated terminals.



Wire Stripping Tool

SKU: 0-704-05

Wire stripping tool for 6 cable sizes up to 5mm. Incorporates cable cutter.



Superseal Crimping Tool

SKU: TT59

Ratchet action ensures correct pressure is applied - adjustable. For reliable and consistent Superseal crimps.



Digital Multimeter

SKU: MultiMeter2

Hand-held digital multimeter with large LCD display for basic functions. Powered by 9 volt battery.

Vintage & Classic Spares Group



SVC is part of the Vintage and Classic Spares group dedicated to providing a wide range of parts and accessories for the veteran, vintage and classic motoring enthusiast.

As well as a huge collection of specialist fittings - many especially commissioned or manufactured by ourselves - we also stock a comprehensive range of Ford parts and engine spares for many types of older vehicle. Please see our other websites for further details or give us a call.



vintagecarparts.co.uk

The leading specialist manufacturer and supplier of parts, and fittings for the restoration and maintenance of vintage and classic vehicles



classicbulbs.co.uk

Over 500 types of Incandescent and Halogen bulbs, plus 200 types of LED bulbs to provide LED replacement and upgrade options for classic and vintage vehicles.



completeautomobilst.com

Est. 1968 to provide veteran, vintage and classic car parts for the restoration of all older vehicles. Many obsolete parts and bespoke items.



tobyvintage.com

Authentic reproduction vintage projector headlamps hand-made in Great Britain, mirrors and improved period rear lamps with LED upgrade options.



flexolite.co.uk

The leader in the supply of fluid systems for older vehicles. Oil filter adaptors, hoses, pumps and fittings for fuel, oil, water, brake and clutch systems.



smallfordspares.co.uk

Specialist supplier of parts and spares for Ford and Thames side valve vehicles built 1932-1962. Also parts for the overhead valve 105E/123E models.



ford-aquaplane.co.uk

Aquaplane tuning parts - world renowned for enhancing the performance of Ford side valve and 100E/105E engines. Production continues in Malvern.



classicfordspares.co.uk

An expansion of Small Ford Spares line to cover Consul, Zephyr, Zodiac, Corsair, Classic Capri and Cortina Mk1 models. Many unique re-manufactured parts.



classicengineparts.co.uk

Engine parts for cars, commercial and tractors from 1920s to 1980s - including bearings, bushes, pistons, rings, liners, valves, guides, seals, gaskets and more.

Terms & Conditions

1. Application of these Terms and Conditions

These Terms and Conditions will apply to all orders for products placed on any of the websites listed below and via our sales team which utilise our delivery services.

www.vintagecarparts.co.uk
www.completeautomobilist.com
www.smallfordspares.co.uk
www.classicfordspares.co.uk
www.fordaquaplane.co.uk
www.s-v-c.co.uk
www.classicengineparts.co.uk
www.flexolite.co.uk
www.classicbulbs.co.uk
www.tobyvintage.com

They govern your contract with us for (i) the sale of products; and (ii) delivery services. Your contract for the purchase and delivery of our products will be with Vintage Supplies Limited. Our registered address is Unit 7 Merebrook Business Park, Hanley Road, Malvern, Worcestershire WR13 6NP, Company Number 02099573. You can contact our team regarding any queries relating to these Terms and Conditions and orders you place using the following contact details: Phone: +44 (0)1684 212882 Email: info@vintagesupplies.com

2. Description of Products

We take all reasonable care to ensure that all details and descriptions are correct however should you feel that there are any misrepresentations please advise us so that we may amend it if necessary. The use of original numbers does not indicate supply of original parts. We reserve the right to supply pattern/remanufactured parts as necessary. It is the purchaser's responsibility to ensure and check that parts supplied are suitable for the vehicle and intended use, and the supplier gives no warranty express or implied of suitability.

3. Order Placement via Website

Once all required products have been added to the online Shopping Cart you will need to Select the Shipping Country using the drop-down list. You must then Select Rate and will be offered the available delivery options. The charges displayed at this stage are not final and are based on the minimum rate for a 0.5kg package. We reserve the right to amend the charge based on the actual weight and dimensions of the final order however if this leads to a difference of more than 10% of total order value you will be contacted for authorisation prior to despatch. Approximate Shipping Charges are displayed in the table below the Shopping Cart. You confirm your consent to this charge when you submit your order.

3.1 How to review your order

At checkout you will be given an opportunity to review your order, including the country of delivery, to make any amendments prior to placing an order. If you make an error in the order you place, please contact customer services on the contact details above as soon as possible, so they can advise.

3.2 Placement and acknowledgement of your order

You place the order for your products on the website by pressing the "Checkout Now" button at the end of the checkout process. You will be guided through the process of placing an order by a series of simple instructions on the website. We will send you an order confirmation email detailing and acknowledging the products you have ordered. This order confirmation email does not constitute an acceptance of your order.

3.3 When your order is accepted and your products are despatched

Order acceptance and completion of the contract between you and us will take place when you receive a despatch email, unless we have notified you that we do not accept your order.

Non-acceptance of an order may be a result of one of the following:
The product you ordered being unavailable from stock;
Our inability to obtain authorisation for your payment;
The identification of a pricing or product description error;
We reserve the right to withhold product supplies from any person

or company

4. Order Payment

We accept payment via Visa and Mastercard debit and credit cards, Paypal, bank transfer, cheque and, in the case of counter sales only, cash. If you are placing the order on the website and wish to pay by any means other than debit or credit card please submit an enquiry and a proforma invoice will be emailed with details of how to pay.

For most products, if you choose to pay via your credit or debit card you will be charged when we despatch your order, this excludes special order and customised products when we will charge your card at the time we place the order with our supplier. If paying by any other means we will verify funds have been received prior to despatch.

Trade account payment terms are 30 days EOM, so payment is due 30 days after the end of the month in which the invoice was received. Monthly statements will be sent via email and we reserve the right to charge interest on outstanding accounts, at a rate in excess of current bank rate.

The contract will be concluded in English.

We only accept payment in Pound sterling (GBP). We're unable to offer the option to pay in local currency. International credit card providers or banks will determine the exchange rate; if payment is made in a currency not issued as standard by the bank, they may add an additional processing or administration charge which the cardholder will be liable to pay.

The details of your specific contract will not be filed by Vintage Supplies Ltd. If you do require any information regarding orders you have placed with us, please contact our Customer Services Team using the contact details above.

Goods remain the property of Vintage Supplies Ltd until payment is received in full.

How to cancel an order and return Products

5. Order Cancellation

The right to cancel allows you time to examine the goods. The cooling off period starts when the contract is concluded and ends 7 working days after the day the goods are received. The right to cancel excludes special order and customised items, for example rubbers and materials which have been cut off rolls, shock absorbers, number plates and leather belts.

When you exercise the right to cancel you are under a duty to take reasonable care of the goods and to return them to us in the condition they were supplied. It is your responsibility to cover return postage costs and it is advised that returned items be sent via recorded mail as we cannot be responsible for lost items.

6. Missing, Incorrect, Damaged or Faulty Items

If any products are missing, incorrectly picked, damaged or faulty, we must be notified on receipt of goods. If goods are sent by carrier sign "damaged" if apparent. You may cancel the order and receive a refund, or request a replacement. This right shall be available for a maximum of 7 days from delivery.

Please contact the sales team using the contact details above who will provide advice and arrange a free return and/or a replacement where applicable, please do not send any items independently as we will not guarantee to reimburse your expense.

We will reimburse to you (by the method used to pay for the original transaction) the cost of the products and delivery, provided no further products within the order were retained, within 30 days of receipt of the returned products.

Please note that this refund will be made in the currency used to pay for the original transaction.

6.1 International Duties and Taxes

We will cover the delivery charges and all relevant duties and taxes for replacement products despatched as a result of a picking error, fault or damage. Please see Section 8 for further details regarding International Duties and Taxes.

Terms & Conditions

6.2 Special Order Products or Products made to your specification

If a special order or customised product is faulty or damaged please contact our sales team for further information and advice

7. VAT

VAT is applicable at the standard UK rate on all orders delivered to a UK postal address, this applies even if the invoice address is international.

The order confirmation email and subsequent invoice will itemise VAT for all product lines and delivery.

Where you have requested delivery to a Non-UK address, the products and the delivery service will be zero-rated i.e. not subject to UK VAT however there will be local duties and taxes payable prior to delivery. See further details below.

8. Import Duty and Tax Payments and Customs - International orders only

Products delivered to destinations outside the UK may be subject to taxes, fees, customs duty, levies or other charges as a result of local legislation or customs formalities. These charges are calculated by our shipping agent and the recipient of the products, which may not be the person placing the order, will typically receive a separate request for payment of these charges when the goods arrive in the country of destination. If you're ordering products to be delivered to someone else, please ensure they're aware that they'll be responsible for these additional charges. Payment by you or the recipient (as applicable) must be received by the relevant customs authority before delivery of the Products will be made.

Unfortunately we have no control over these charges and cannot predict what they may be, so we are unable to offer any assistance on these processes. We advise that you check any customs formalities and the import charges applicable in any country before ordering products to be delivered there. We will use commercially reasonable efforts to provide you with information which we hold which relates to the product or order which you may need in order to arrange customs clearance.

You (or the recipient of the products if different) will be the importer for all international deliveries of the products. Therefore, before placing an order, it's your responsibility to check that any products ordered comply with country, state and/or federal government import regulations, and that there are no local requirements or restrictions which may affect receipt of your order.

You agree that we will act on your behalf as exporter of the products and will complete export declarations in our own name on your behalf.

If an order is placed and restrictions that we were not aware of at the time the order was made are applied by the customs authority of the destination country, then we will cancel the order and return payment to you.

We, or our shipping agents, may request information from you in relation to customs formalities. You must respond to any request for information within 5 days of the request, or the order will be cancelled.

If the recipient wishes to return the product(s), they must request a refund of the customs duties and tax directly with their local customs office and must present proof of return. As the process varies by country and is subject to regular legislative amendments we can not provide any further advice on this.

9. Delivery Charges

To minimise delivery charges we do not finalise the delivery charge at the time you place the order, a minimum rate based on the despatch of a 0.5kg package using the selected delivery option is preliminarily added to your shopping cart.

We reserve the right to amend the charge based on the actual weight and dimensions of the final order however if this leads to a difference of more than 10% of total order value you will be contacted for authorisation prior to despatch. Approximate Shipping Charges are displayed in the table below the Shopping Cart.

You confirm your consent to this charge when you submit your order.

10. Lead Times

We supply almost all products direct from our extensively stocked warehouse so, with the exception of special order and customised products where lead times will be specified within the product details, we endeavour to process orders on receipt. Occasionally, some items will not be ex-stock and will be marked 'to follow' on the invoice and despatched immediately new stock arrives. You will only be charged once for shipping.

Delivery lead times to international addresses will vary according to destination but we will use reasonable endeavours to ensure that all products will be delivered within 30 days from the conclusion of the contract with us. In the event that your order has been despatched by us (as confirmed in the despatch confirmation e-mail) but has not arrived within the estimated delivery time range, please contact our sales team on the contact details above. If delays outside of our control occur, we will make every effort to keep you informed.

11. Privacy

In accordance with our Privacy Policy, we may disclose your relevant personal information pertaining to your order, to other firms we or they work with (such as delivery service providers) in order to process, deliver your order to you, and to keep you informed of any updates regarding your order. To read more on how your personal data is going to be handled, read our full Privacy Policy.

12. Limitation of Liability

We accept liability only for items which are proved faulty by reason of our negligence. Such liability is limited to the price paid for the item and does not include any consequential loss.

13. Severance and Survival

If any part of these Terms and Conditions shall be found by a Court to be unlawful, void or unenforceable for any reason, then that provision shall be capable of being severed and separated from these Terms and Conditions and shall not affect the validity and enforceability of any of the other provisions of these Terms and Conditions which shall all remain in force.

14. Entire agreement

You confirm that, in agreeing to accept these Terms and Conditions, you have not relied on any representation made to you other than those contained in these Terms and Conditions and you agree that you shall have no remedy in respect of any such additional representation. Your statutory rights are not affected by these Terms and Conditions.

15. Jurisdiction

These Terms and Conditions shall be subject to English law. All claims or disputes arising in relation to or in connection with any contract (any order for Products) under these Terms and Conditions shall be governed by English law.





Product
CATALOGUE

CONTACT

Unit 7 Merebrook Business Park
 Hanley Road, Malvern
 Worcestershire WR13 6NP
 Tel: **+44 (0)1684 219 863**
 Email: admin@s-v-c.co.uk



www.s-v-c.co.uk

Stafford Vehicle Components is a trading entity of the Vintage and Classic Spares group including Vintage Supplies Ltd, The Complete Automobilst, Small Ford Spares, Classic Ford Spares, Flexolite, Classic Engine Parts, Classic Bulbs & Toby Vintage